

COMPLEX BEAM PROFILE RECONSTRUCTION, A NOVEL ROTATING ARRAY OF VIBRATING WIRES

Alonso J., Massachusetts Institute of Technology, USA
 Arutunian S.G., Yerevan Physics Institute, Yerevan, Armenia

Abstract

Proton/ion beams of multiple charge/mass ratios can be very complex. Orthogonal X-Y projections are often inappropriate to represent these profiles. An array of vibrating wires, rotating around the beam axis is under development. The mechanical implementation is described. An algorithm to reconstruct the profile is proposed. The tradeoffs between the number of wires, the rotation angles, the response time and the profile resolution are discussed.

INTRODUCTION

We suggest to use vibrating wires as an instrument that integrates the beam particles energy depositions into the wire temperature increase. The response of such heating comes out as vibrating frequency shift. So the signal from the wire is formed as a singled frequency measurement that allows usage of many wires simultaneously. Rotating around the beam axis, array of vibrating wires may be helpful for the measurements of the complex profiles of the beam particles.

Signal recovery in this case can be very similar to the methods widely used in tomography (see e.g. [1, 2]). We propose to apply the filtered back-projection algorithm [2], which is widely used in almost all applications of straight ray tomography.

This algorithm was evaluated on the complicated profile beam with formal usage of 100 wires rotated at 100 angle positions.

Ten vibrating wire array monitor with mechanism of rotation and extraction from beam aperture is developed and discussed.

BACK-PROJECTION METHOD

Following [2] we consider two dimensional area with **non-uniform** distribution $\mu(x, y)$ and possibility by some detection system to provide so called projections $p(\xi, \theta)$ of this distribution along any axis with angle θ relative to axis x :

$$p(\xi, \theta) = \int_{-\infty}^{+\infty} \int_{-\infty}^{+\infty} \mu(x, y) \delta(\xi - x \cos \theta - y \sin \theta) dx dy. \quad (1)$$

Back-projection for a given angle θ is a mathematical operation that spreads back this projection **uniformly** over the **strip** $\xi = x \cos \theta + y \sin \theta = \text{const}$ in distribution area:

$$b(x, y, \theta) = p(x \cos \theta + y \sin \theta, \theta). \quad (2)$$

Integrating over θ gives distribution $g(x, y)$, which approximately represents the initial distribution $\mu(x, y)$:

$$g(x, y) = \frac{1}{2\pi} \int_0^{2\pi} b(x, y, \theta) d\theta. \quad (3)$$

The process of projection we illustrate on the sample of following distribution in discrete space 70x70:

$$\begin{aligned} \mu(x, y) = & 10 \exp\left(-\frac{(x-10)^2 + y^2}{25}\right) + \\ & + 7 \exp\left(-\frac{(x-10)^2 + y^2}{25}\right) + 10 \exp\left(-\frac{(\sqrt{x^2 + y^2} - 30)^2}{100}\right) \end{aligned} \quad (4)$$

The coloured view of this distribution is presented on Fig. 1. The square 70x70 is placed in larger working area 100x100 for possibility of distribution rotations.

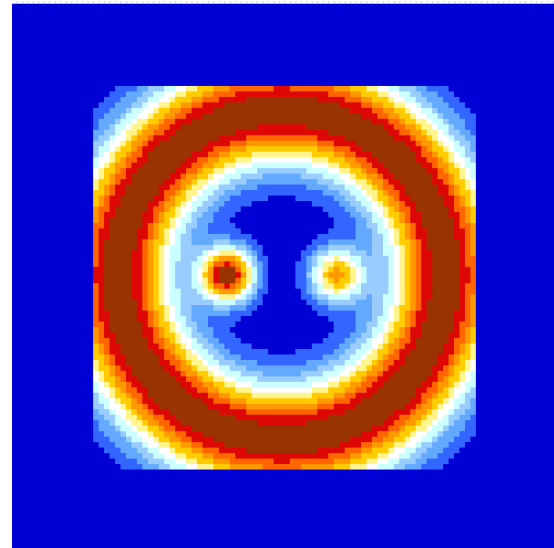

Figure 1: Test distribution of the beam to be measured.

The projection of this distribution according to (1) in vertical direction is presented on Fig. 2. Simple reconstruction algorithm (2-3) gives result presented in Fig. 3 (vertical axis – number of wires, horizontal axis – angular position with step $\pi/100$).

From the accurate mathematical theory (see e.g. [3]), it follows that for precise reconstruction the projections should be preliminary "filtered" (convolution technique [4]):

Content from this work may be used under the terms of the CC BY 3.0 licence (© 2014). Any distribution of this work must maintain attribution to the author(s), title of the work, publisher, and DOI.

$$f(\xi, \vartheta) = \int_{-\infty}^{+\infty} \int_{-\infty}^{+\infty} p(\xi_0, \vartheta) h_1(\xi - \xi_0) d\xi_0, \quad (5)$$

where

$$h_1(\xi) = \frac{1}{4\pi} \int_{-\infty}^{+\infty} |\chi| \exp(i\chi\xi) d\chi \quad (6)$$

Usage of $f(\xi, \vartheta)$ instead of $p(\xi, \vartheta)$ in (2) and (3) recovers the initial distribution $\mu(x, y)$. Similar correction function can be derived entirely in the spatial domain rather than frequency domain with some inherent approximations [5].

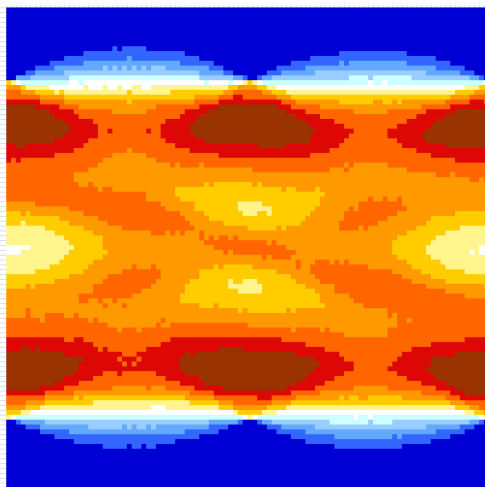

Figure 2: Projections plot of the test distribution.

The concept of developed for image reconstruction correction function in first approximation leads to adding contribution from neighbouring wires of a chosen strip in back projection algorithm with negative weight-factor about -0.5 (result is presented at Fig. 4).

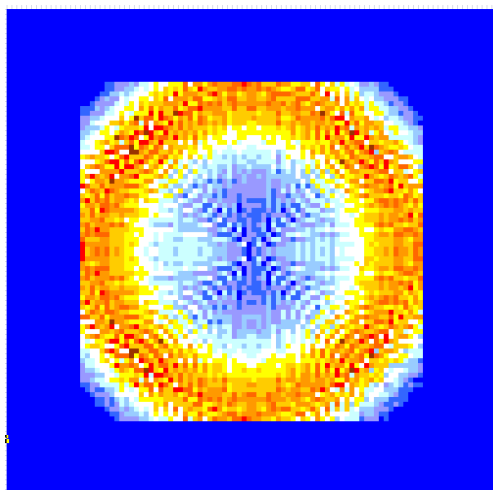

Figure 3: Direct back-projection reconstruction.

WIRE AS-PROJECTION MEAN

As a detection instrument we suggest to use array of vibrating wires. Each wire at a certain position

accumulates the energy of beam particles penetrating the wire, which results in the increases of the wire temperature. Wire heating leads to natural oscillation frequency change that can be measured very precisely (see e.g. [6]). Unlike the commonly used wire scanners the information on each wire is concentrated into the wire's generated current signal that allows to use many wires simultaneously.

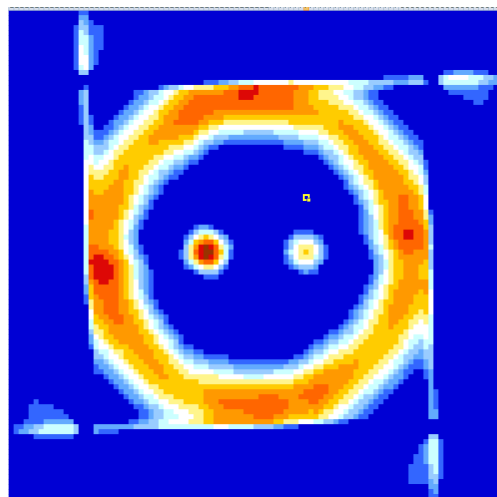

Figure 4: Distribution (4) reconstruction with correction function.

VWM-HARPSICHORD

Following J. Bergoz, we name the array of vibrating wires as "Vibrating wires monitor - Harpsichord" or "VWM-Harpsichord".

The main demand for VWM-Harpsichord construction is possibility of rotation along the beam axis and also possibility to remove array of wires from beam aperture.

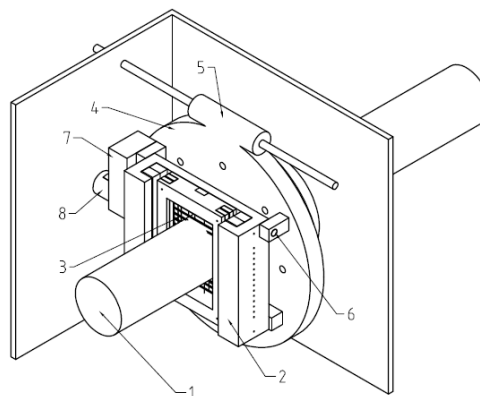

Figure 5: Numerals indicate: (1) – measured beam, (2) – frame of monitor, (3) – vibrating wires, (4) –support flange with gear teeth on the flange rim, (5) – loading gear with shaft translated rotation, (6) –inclination axis supporting lips, (7) – gearbox-transmitter translate inclination axis rotation to the shaft (8).

In case of the beam diameter up to 50 mm we propose to use 10 wires array with length of 80 mm. The space between magnet poles opened for beam is evaluated as 50 mm. The frame of VWM-Harpsichord is estimated about

125 mm x 125 mm. To avoid difficulties with vacuum conditions in the chamber we suggest to rotate VWM-Harpsichord with the help of bearing with through-hole diameter about 100 mm. Immovable support of bearing inner ring should be mounted on the normal to the beam axis front wall of special vacuum chamber. Rotating outer ring of bearing should carry the supporting VWM-Harpsichord flange with external teeth. Special gearwheel with small diameter is proposed to execute rotation of this support flange. This gearwheel should pass the sidewall of the vacuum chamber via high vacuum rotary motion feedthrough. The described construction of the VWM-Harpsichord is presented at Fig. 5.

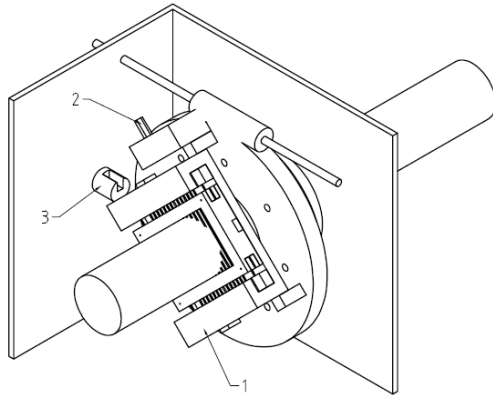

Figure 6: Monitor (1) inclination axis mechanical gearbox is terminated with shaft (2) that, at initial angle position, is plunged into the slot of the shaft (3), which translates the rotation outside of the vacuum chamber.

The inclination of the VWM-Harpsichord relative to flange plane is proposed to be done by rotating monitor inclination axis in the lips (see Fig. 5). Gearbox-transmitter translates rotation to the shaft that at starting angle is plunged into the special slot (see Fig. 6).

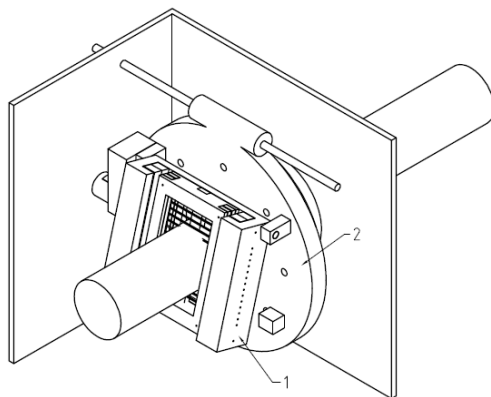

Figure 7: Rotation of the monitor (1) can be done at any inclination angle relative to flange (2) plane.

Thereby for VWM-Harpsichord rotation and inclination at start position only two rotary motion feedthroughs are

expected. Rotation of the VWM-Harpsichord can be done at any inclination angle (see Fig. 7). At inclination angle 90° VWM-Harpsichord completely removed from the beam aperture.

The vacuum chamber sizes are expected as 240 mm x 240 mm (front wall) x 200 mm.

DISCUSSION

There are two main criteria for VWM-Harpsichord parameters selection: the number of the wires and their length. The length of the wire should be about half larger than the beam transversal size and defines the response time of the monitor. For Tungsten wires this parameters is about 10 s [7] and defines the same measurement time for one projection of the beam. Spacing between wires should be about few mm to avoid thermal interference between wires. So for 50 mm aperture number of wires can be about 10. Ten rotation positions should fill angle π .

ACKNOWLEDGMENTS

Authors are grateful to J.Bergoz for research initialization and the permanent support.

REFERENCES

- [1] G.L. Zeng, Medical Image Reconstruction. A Conceptual Tutorial, Higher Education Press, Beijing and Springer-Verlag Berlin Heidelberg 2010.
- [2] A.C.Kak, M.Slaney, Principles of Computerized Tomographic Imaging, SIAM, Philadelphia, 2001.
- [3] С.А.Терещенко. Вычислительная томография. Часть 1. М., МИЭТ, 1995, http://bms.miet.ru/vt/0_um/part1/part_1_5.html
- [4] G.N. Ramachandran, A.V. Lakshminarayanan, Three-dimensional Reconstruction from Radiographs and Electron Micrographs: Application of Convolutions instead of Fourier Transform, Proc. Nat. Acad. Sci. USA, Vol. 68, No. 9, pp. 2236-2240.
- [5] Z.H. Cho, I.S. Ahn, and C.M. Tsai, Computer algorithms and detector electronics for the transmission X-ray tomography, Trans. Nucl. Sci; NS-21(1), 218-227.
- [6] S.G. Arutunian, Proceedings of Beam Instrumentation Workshop, BIW'08, Lake Tahoe, MI 2008 (LBNL, Berkeley), pp. 1-7.
- [7] S.G. Arutunian, A.E. Avetisyan, M.M. Davtyan, G.S. Harutyunyan, I.E. Vasiniuk, M.Chung V.Scarpine, Large aperture vibrating wire monitor with two mechanically coupled wires for beam halo measurements, Phys. Rev. ST-AB, 17, 032802 (2014).