

MULTI-TURN ERL-BASED SYNCHROTRON LIGHT FACILITY: INJECTOR DESIGN*

A.N. Matveenکو[#], T. Atkinson, A.V. Bondarenko, Y. Petenev, HZB, Berlin, Germany

Abstract

Multi-turn energy recovery linac based light sources are candidates for the future 4th generation synchrotron light sources. Using the superconducting linac technology, the Femto-Science-Factory (FSF) will provide its users with ultra-bright photon beams of angstrom wavelength at 6 GeV final beam energy. The FSF is intended to be a multi-user facility and offers a variety of operation modes. An overview of the machine layout and magnetic optics design of the installation will be given in this paper with the focus on high brightness injector design.

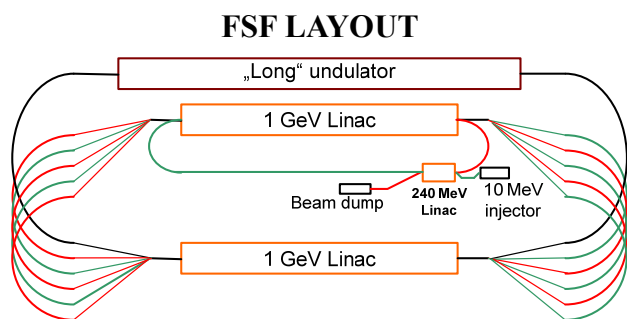

Figure 1: General layout of the FSF. Green lines – beam at acceleration, red – at deceleration, black – 6 GeV beam.

The accelerator layout is shown schematically in the Fig. 1. It consists of a 10 MeV high brightness photo injector, medium energy (240 MeV in the picture) second stage injector, main linac, which is split into 2 1-GeV linacs (similar to CEBAF design). Each of the 1 GeV linacs is passed 3 times by the beam to gain 6 GeV, deceleration takes place in the reverse order. The details of the beam optics, operation modes, proposed undulators, etc. see [1,2].

The beam and accelerator parameters are summarized in Table 1.

In this paper a summary of the design and results of beam dynamics simulation of FSF 10 MeV injector for 3 operating modes with different bunch charge is given.

INJECTOR

Beam parameters (transverse and longitudinal emittance) achieved in the injector is the key to the maximal brilliance of the FSF. They also define the efforts one should take for the design of the rest of the accelerator, since preserving the emittances on the desired level is not trivial. The goal for the value of the transverse

emittance 0.1 mm-mrad is challenging but within the reach of the modern guns. Emittance compensation technique must be used to preserve the emittances in the low energy part of the accelerator.

High brightness electron sources generating short pulses are based on the photocathode guns. There are a number of operating photocathode sources in DC guns, normal conducting radiofrequency (RF) guns, and superconducting RF (SRF) guns. The latter have the highest potential for the future high brightness sources since they combine the advantages of cw operation, high peak field on the cathode, and excellent vacuum conditions (of advantage for the life time of high QE semiconducting photocathodes). Due to these reasons an SRF gun is considered as a base line design for the FSF. However, the excellent results of the Cornell ERL Injector group [3] show, that even a much more technologically mature solution with a DC photocathode gun could be sufficient for FSF needs.

Space charge effects in the injector are strong and limit the bunch charge. Modeling of the beam dynamics must be done with an appropriate space charge modeling program. We use ASTRA code (version 3) by K. Flöttmann [4].

The layout of the injector is shown in Fig. 2. From the beam dynamics point of view it consists of a superconducting RF photo gun and booster in a single cryomodule, merger section and two matching sections of 4 quadrupoles each.

A long laser pulse is necessary to generate the 0.1 mm-mrad transverse emittance bunch with maximal charge. This initially long bunch must be compressed further. A 3rd harmonic cavity is used to linearize the longitudinal phase space of the bunch for the compression.

As a merger section 4-dipole bypass is proposed. The advantage of the chicane in our case is the absence (at least in the ideal world) of dispersion to all orders. This is important, since quite large (~1%) energy spread in the bunch is needed for the compression. With other merger types (e.g. dogleg) second order dispersion would be detrimental for the transverse beam emittance. The bypass dipoles are 20deg 30 cm long. The distance between them ($L=1.10$ m) defines R_{56} of about 25 cm (needed for the bunch compression) and trajectory offset $D\sim 50$ cm, which should be enough to install the high energy beam line elements. Four quadrupole magnets between the booster and merger and four between merger and pre-injector linac are necessary for the transverse beam matching and emittance compensation. Two (weak) quadrupoles in the chicane are for the possible correction of the “space charge dispersion”.

*Work supported by grants of Helmholtz Association VH-NG-636 and HRJRG-214.

[#]aleksandr.matveenکو@helmholtz-berlin.de

Content from this work may be used under the terms of the CC BY 3.0 licence (© 2014). Any distribution of this work must maintain attribution to the author(s), title of the work, publisher, and DOI.

Table 1: Main Parameters of the Multi-turn ERL. Beam brilliance in 3000 period undulator in low emittance mode and 1000 period arc undulators for high brilliance and short pulse modes is given.

Accelerator/beam parameters	Low emittance mode	High brilliance mode	Short pulse mode
E, GeV	6	6	6
$\langle I \rangle$, mA	20	6.5	1.3
Q, pC	15	5	1
$\epsilon_{L,n}$, x/y mm	0.25/0.10	0.35/0.11	0.22/0.09
ϵ_t , keV·mm	320	21	7.8
τ , fs	1500	25	~10
$\langle B \rangle$, $\frac{Ph}{s \cdot mm^2 mrad^2 0.1\%}$	$4.0 \cdot 10^{22}$	$2.6 \cdot 10^{21}$	$8 \cdot 10^{20}$
B_{peak} , $\frac{Ph}{s \cdot mm^2 mrad^2 0.1\%}$	$5.4 \cdot 10^{24}$	$2.0 \cdot 10^{25}$	$\sim 1.5 \cdot 10^{25}$

Table 2: Beam Parameters from Injector

Accelerator/beam parameters	Low emittance mode	High brilliance mode	Short pulse mode
Beam momentum pc, MeV	50	50	50
Max average beam current, mA	20	6.5	1.3
Bunch charge, pC	15	5	1
Longitudinal emittance (rms), keV·mm	9	2.5	0.75
Bunch length (rms), ps	3	2.0	0.62
Normalized emittance (ϵ_x/ϵ_y , rms), mm·mrad	0.13/0.10	0.11/0.06	0.18/0.08

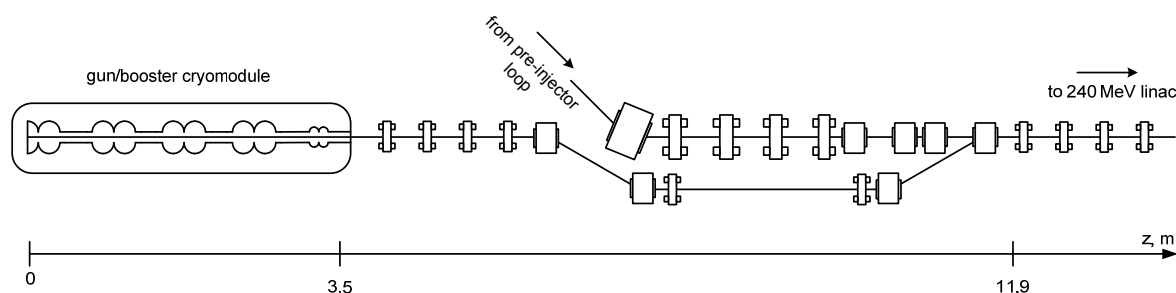

Figure 2: Layout of FSF injector.

A solenoid usually used for the emittance compensation in high brilliance guns has quite strong aberrations which limit the beam size in the solenoid. On the other hand, in an SRF gun the solenoid cannot be positioned close to the gun cavity since the cavity quality factor Q is vulnerable to residual fields at cool down as well as in operation. Therefore, another solution for the beam focusing after the gun is chosen: focusing with the RF field of the first cavity in the booster. This way this unavoidable and quite strong focusing is used to benefit. Additionally, this allows putting the gun and the booster in a single cryomodule.

Cathode Laser Considerations

We start with a particle distribution on the cathode (see Fig. 4.). The transversally flat-top laser spot profile on the cathode is assumed with a radius of 0.2 mm. The longitudinal profile of the beam is also flat-top (plateau distribution) with a 50 ps length and 5 ps rise/fall time (rms. length of ~15 ps).

Beam Parameters in the FSF Injector

Main beam parameters at injection are summarized in Table 2 for the three operation modes. It is necessary to run ASTRA modelling up to the beam energy of 50 MeV, where the emittance compensation is complete. See Fig. 3 for the linac layout used in the model. The quadrupoles in the injection beamline are optimized for minimum emittance. For details on the emittance compensation of beams without axial symmetry see e.g. [5,6]. Longitudinal dynamic (compression) was optimized individually for the three modes.

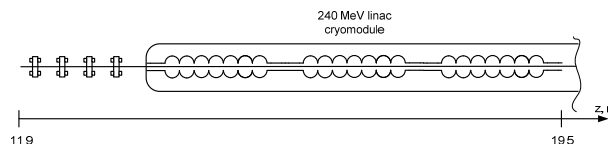

Figure 3: Sketch of the part of pre-injector linac used in ASTRA modeling to ensure the emittance is frozen after emittance compensation.

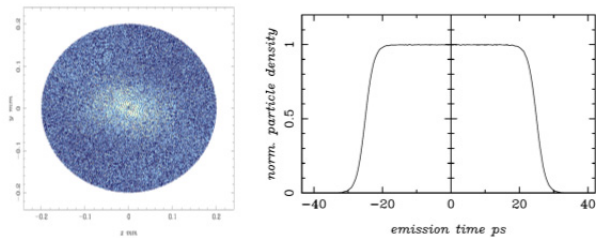

Figure 4: Laser spot at the cathode (left) and time profile of the laser (right).

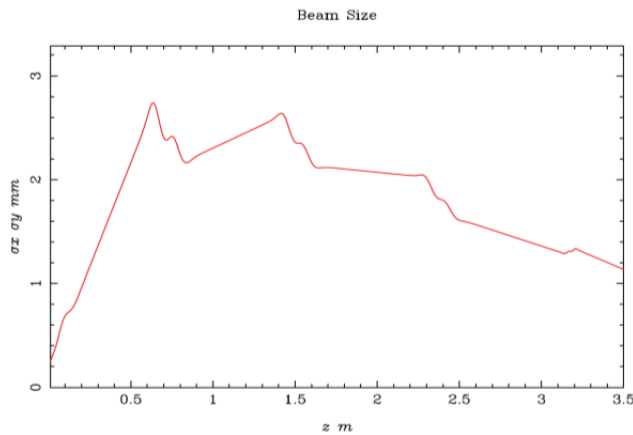

Figure 5: Transverse beam size in the gun/booster cryomodule in low emittance mode.

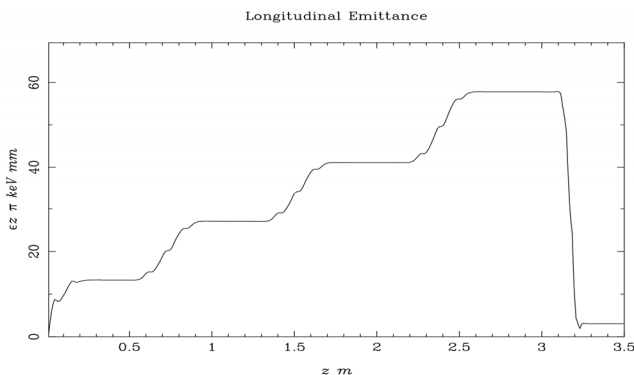

Figure 6: Longitudinal emittance in the FSF injector. 3rd harmonic cavity at ~3.2 m is used for linearization of the longitudinal phase space.

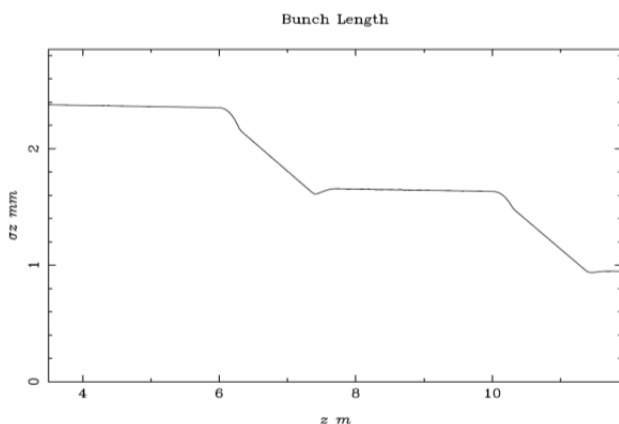

Figure 7: Bunch length in the merger section.

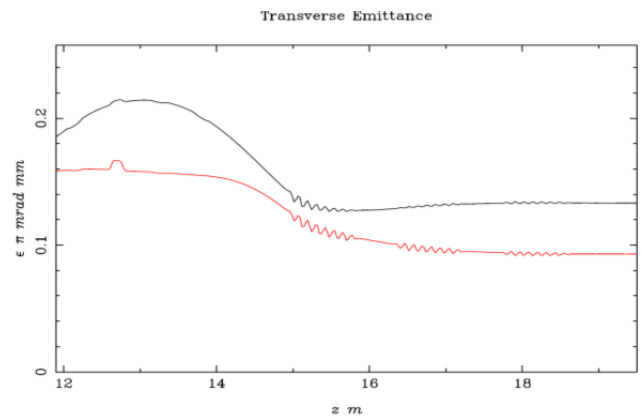

Figure 8: Projected emittances in the linac section (black - x, red - y). Last stage of the “emittance compensation” can be seen.

Plots of the beam parameters in low emittance mode are shown in Figs. 4-8. Final beam parameters for high brilliance and short pulse mode are summarized in Table 2.

CONCLUSIONS

Feasibility of a 10 MeV high current injector for a multi-GeV ERL-based light source is shown. Possible design of such an injector is proposed. Beam parameters for three operational modes are calculated with the ASTRA code.

REFERENCES

- [1] Y. Petenev, T. Atkinson, A.V. Bondarenko, A.N. Matveenko, Analysis of Injection and Recovery Schemes for a Multi-turn ERL based Light Source, Proc. of 53th ICFA Workshop on Energy Recovery Linacs, Novosibirsk, 2013.
- [2] T. Atkinson, A.V. Bondarenko, A.N. Matveenko, Y. Petenev, Start-to-end beam dynamics simulations for Femto-Science-Factory feasibility study, Proc. of 53th ICFA Workshop on Energy Recovery Linacs, Novosibirsk, 2013.
- [3] B. Dunham, et al., “Performance of the Cornell High-Brightness, High-Power Electron Injector”, MOOAA01, IPAC 2012, New Orleans, Louisiana (2012).
- [4] K. Flöttmann, ASTRA - A Space Charge Tracking Algorithm, <http://www.desy.de/~mpyflo/Astra>
- [5] S.V. Miginsky, Space charge effects, coherence of charge oscillation, and emittance, Technical Physics 78(9), 96 (2008).
- [6] A.V. Bondarenko, A.N. Matveenko, Emittance Compensation Scheme for the BERLinPro Injector, IPAC 2011, TUPO028, San Sebastian, Spain (2011).