

KICKER DEVELOPMENT AT THE ELBE FACILITY

Gerald Staats, Andre Arnold, Hartmut Buettig, Timo Kirschke, Michael Kuntzsch, Peter Michel, Jochen Teichert, Hannes Vennekate, Andreas Wagner, Rong Xiang, HZDR, Dresden, Germany
Reinhard Krause-Rehberg, Andreas Mueller, Martin-Luther-Universität, Halle, Germany

Abstract

Kicker/Choppers are needed at ELBE for different purposes. We have three main areas for kickers/choppers:

First: improving the time resolution at the positron beam line using a Chopper to cut parts of the bunch,

Second: reducing the dark current of the SRF-Gun by dumping bunches,

Third: splitting the beam in two parts for made two experiments at the same time.

One part of the work was using CST Particle Studio to simulate different structures for deflecting the bunch in the beam line. Here we have no big differences to known strip line structures.

In the second part we have to design the electronics to drive the kicker/chopper. Contrary to other machines ELBE has a high bunch rate therefore also the kicker/chopper runs at high PRF, in maximum at 13MHz.

This will lead to higher power levels and problems in the driver electronics.

In conclusion we will present the state of our development for all three systems and discuss the solutions.

POSITRON CHOPPER

At the positron facility a chopper is needed to increase the time resolution. From beamline calculation it is estimated that the optimum pulse length would be about 4ns, as seen in Figure 1.

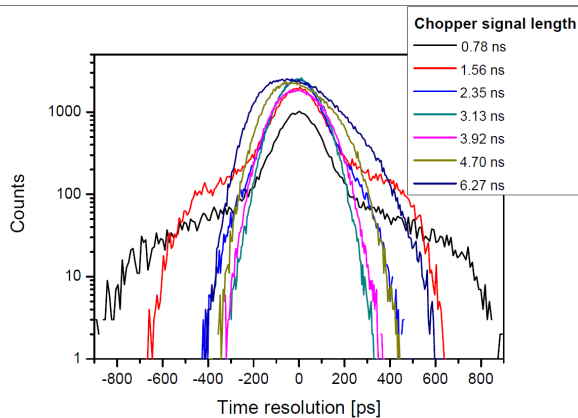

Figure 1: Monte-Carlo simulation over all (including PMT) as function of chopper pulse width. A Gaussian chopper pulse of 3.9 ns FWHM is required to obtain reasonable resolution.

For driving the chopper plates 4 equal channels are needed. The electronics consist of a driver circuit and a half bridge switch [1, 2], shown in Figure 2. In maximum the chopper driver can deliver 300V peak pulses at 13MHz pulse repetition frequency.

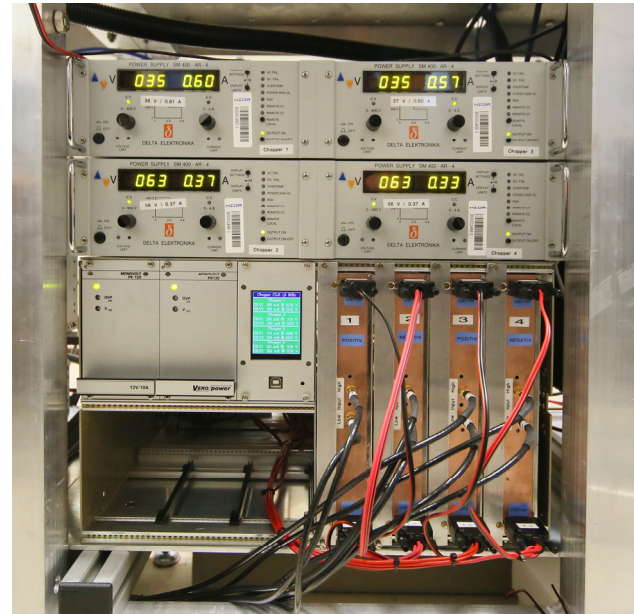

Figure 2: Electronics Cabinet of the Positron Chopper.

The output pulse for a positive channel is shown in Figure 3. Time jitter standard deviation is about 32ps. Rise time is about 3.9ns and fall time is 1.9ns. For the negative channel the results are similar. All 4 channels are shown in Figure 4.

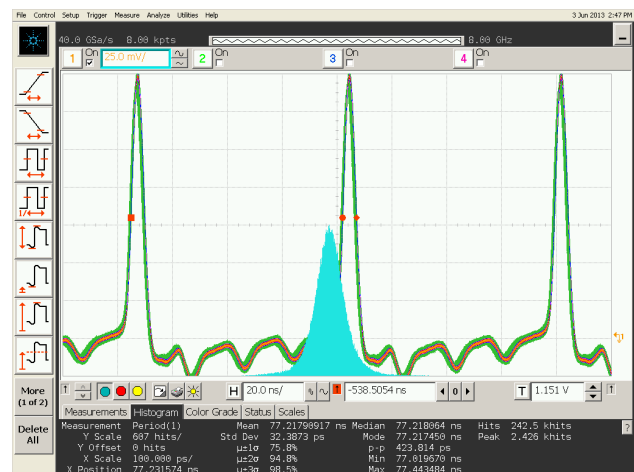

Figure 3: Output pulse and jitter histogram for a positive channel at 13 MHz pulse repetition frequency and 175 V peak voltage.

Content from this work may be used under the terms of the CC BY 3.0 licence (© 2014). Any distribution of this work must maintain attribution to the author(s), title of the work, publisher, and DOI.

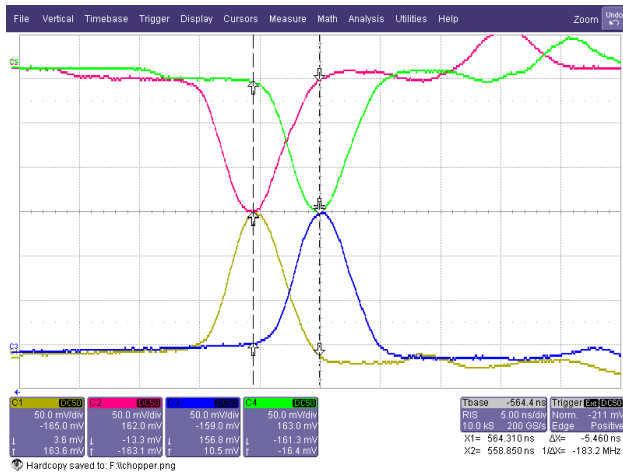

Figure 4: Output pulse of all 4 channels measured after the termination attenuators.

With the chopper system the noise was much reduced, as seen in Figure 5.

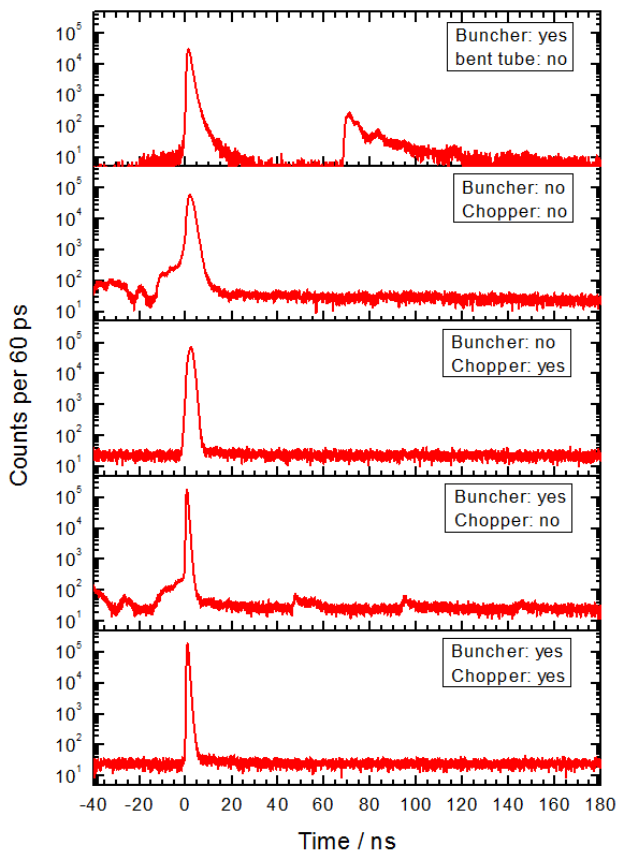

Figure 5: Effect of chopper and buncher.

DARK CURRENT KICKER

The dark current shown in Figure 6 is an undesired and inevitable phenomenon in the RF gun and the SRF gun operation at high acceleration gradients.

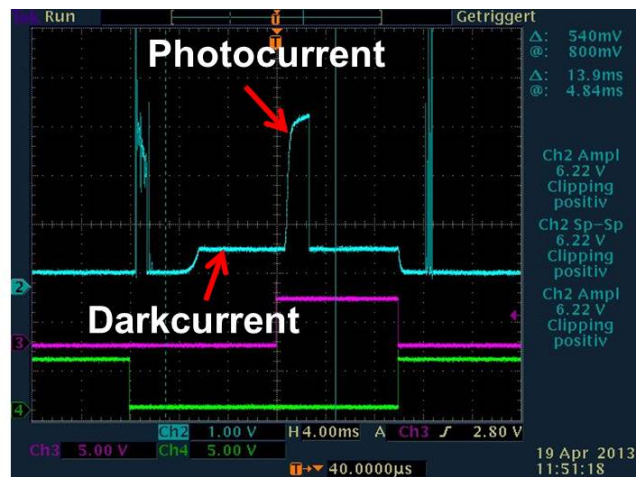

Figure 6: The blue line (top) gives the Faraday cup signal of the sum of the dark current and photocurrent on the oscilloscope, the green line (bottom) gives the macro-pulse signal of the solid state amplifier, and the magenta line (middle) represents the trigger signal of the cathode drive laser.

In order to reduce the dark current before it enters the linac, a kicker in front of the dogleg beam line can be applied. Fast pulsed systems (Kickers) are brightly used for injection and extraction purpose [3-5]. Here, a special kicker design is planned to reduce the unwanted beam. The basic concept is shown in Figure 7. The 13 MHz photoelectron pulses together with the 1.3 GHz dark current bunches enter into the beam line (a). The fast kicker (Yoke-free strip line Kicker) is applied with long pulses of 13 MHz and 5 ns windows (b) resulting 93.5 % of the dark current being kicked out. The passed beam consists of 13 MHz photoelectron pulses together with the dark current bunches in 5 ns macro pulses (c).

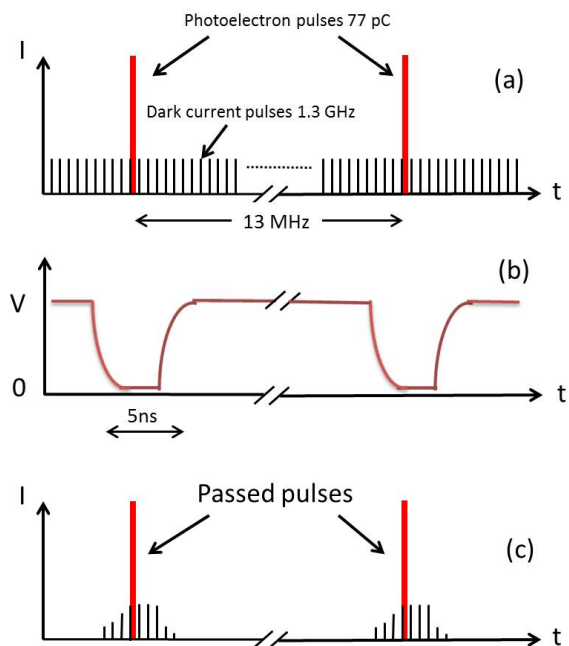

Figure 7: The concept of the kicker designed for SRF gun.

Content from this work may be used under the terms of the CC BY 3.0 licence (© 2014). Any distribution of this work must maintain attribution to the author(s), title of the work, publisher, and DOI.

The first version of the kicker is shown in Figure 8. The total model is 250 mm long with 150 mm strip line length, and a radius of the kicker chamber of 5 mm. A driver with +/- 500 V pulses will be applied. The CST simulation has been done to look into the paths of the particles through the kicker. Electrons with energy of 5 MeV will be deflected 1.06 degree away from the axis to the collimator downstream.

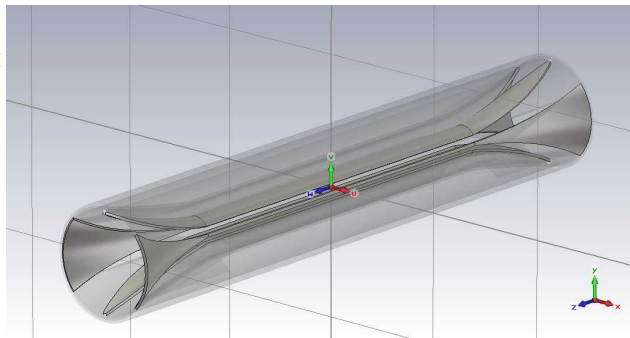

Figure 8: The model of the strip line kicker for the SRF gun, which is 250 mm long with a strip length of 150 mm and 50 mm taper length at each side. The structure consists of two strip lines for kicking the unwanted electron bunches and two ground fenders for homogenizing the field inside.

ELBE KICKER

The purpose of the ELBE kicker is to split the beam in 2 parts, one with a higher bunch repetition rate and one with a lower rate. Due the high energy, in maximum 40MeV, here a much greater voltage is required. The kicker structure is also much longer as in the dark current system [3-5], but has similar geometry, see Figure 9.

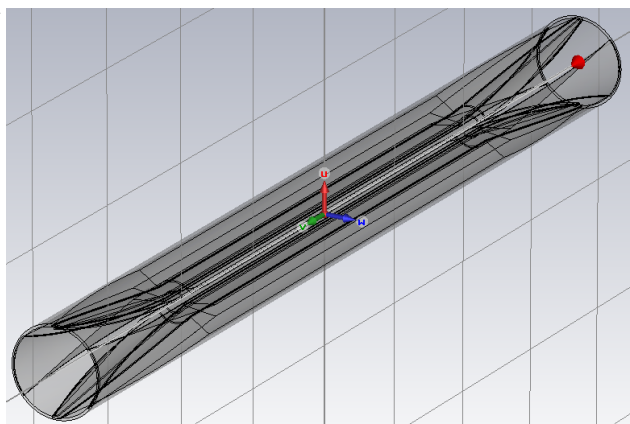

Figure 9: The model of the strip line kicker for the ELBE kicker, which is 740 mm long with a strip length of 375 mm and 182.5 mm taper length at each side. The structure consists of two strip lines for kicking the electron bunches and two ground fenders for homogenizing the field inside.

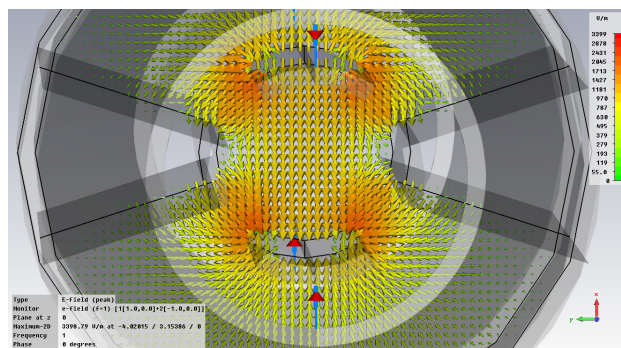

Figure 10: Electric-field inside the the strip line kicker for the ELBE LINAC.

After some calculation it is estimated for the given deflecting angle that a voltage about $\pm 2000V$ is needed. By forming the kicker electrodes a mostly flat field distribution was reached, as shown in Figure 10. The maximum pulse repetition frequency for the ELBE kicker would be 6.5 MHz.

For the half bridge switches in this system a special version of Behlke HTS 50-05 [6] was developed, which is capable to drive the kicker electrodes at 6.5MHz pulse repetition frequency. On-Time of this switch will be about 25ns.

CONCLUSION

The development of the positron chopper is nearly finished and has shown good results.

The other two kickers are in progress with the simulations and also with the hardware developing.

ACKNOWLEDGMENT

We would like to appreciate the support of our Department of Research Technology.

REFERENCES

- [1] DRF Series Design Guide, Application Note 1815, Microsemi Power Products Group (former APT), January 2011.
- [2] 3kW and 5kW half-bridge Class-D RF generators at 13.56 MHz with 89% efficiency and limited frequency agility, IXYS Corporation, 2002.
- [3] Ultra Fast Hybrid MOSFET/Driver Switch Module R&D for a Broadband Chopper, Tao Tang, Craig Burkhart, Power Conversion Department, SLAC National Accelerator Laboratory.
- [4] Development of a Fast High-Power Pulser and ILC DR Injection/Extraction Kicker, Anatoly Krasnykh (SLAC), ILC Damping Ring R&D Workshop, Cornell University, September 26-28, 2006.
- [5] Fast Kicker Driver for ILC Damping Rings SBIR Phase II Contract # DE-FG02-06ER84459.
- [6] HTS 50-05, Fast High Voltage Transistor Switches, Behlke, <http://www.behlke.com/pdf/160-01.pdf>.