

RF DESIGN AND OPERATION OF A MODULAR CAVITY FOR MUON IONIZATION COOLING R&D*

D. Bowring, M. Palmer, K. Yonehara, Fermilab, Batavia, IL 60510, USA
Y. Torun, Illinois Institute of Technology, Chicago, IL 60616, USA

Abstract

Ionization cooling channel designs call for the operation of high-gradient, normal-conducting RF cavities in multi-Tesla solenoidal magnetic fields. However, strong magnetic fields have been shown in some cases to limit the maximum achievable gradient in RF cavities. This gradient limit is characterized by RF breakdown and damage to the cavity surface. To study this issue, we have developed an experimental program at Fermilab's MuCool Test Area (MTA) based on a modular pillbox cavity operating at 805 MHz. The modular cavity design allows for the evaluation of different cavity geometries and materials – such as beryllium – which may ameliorate or circumvent RF breakdown triggers. We present a summary of recent results and plans for the future of the MTA normal conducting RF cavity program.

MUON IONIZATION COOLING AND THE MUCOOL TEST AREA

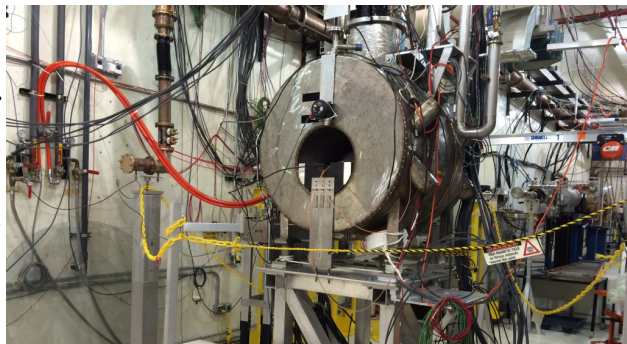

Figure 1: Photo of the MTA experimental hall showing the large-bore 5 Tesla superconducting solenoid (center), RF power and cryogenic delivery systems, 400 MeV H^- beamline (right), and safety and diagnostic instrumentation. Not shown: LHe cryogenic plant, portable clean room.

The half-life of a muon at rest is 2.2 μ s. Muon beams must therefore be cooled more quickly than traditional methods (e.g. stochastic cooling) allow. Ionization cooling seems to be the most rapid, efficient approach to cooling muon beams [1].

Ionization cooling channel designs call for the placement of RF cavities within multi-Tesla solenoidal magnetic fields. However, applying strong magnetic fields to normal-conducting RF cavities has the effect of limiting their maximum achievable accelerating gradient. This limitation is

characterized by an increased RF breakdown rate and damage to the cavity surface. Such effects have been observed at multiple RF frequencies and in several different cavity geometries [2, 3].

Fermilab's MuCool Test Area (MTA) is an experimental facility uniquely suited to perform R&D related to the design of a viable ionization cooling channel for a future muon accelerator. The experimental hall features a large-bore, five Tesla superconducting solenoid capable of housing 805 MHz RF cavities; RF power systems that deliver 12 MW at 805 MHz and 4.5 MW at 201 MHz; a 400 MeV H^- beamline; a class-100 portable clean room for assembly and cavity inspection; and a full suite of diagnostic and safety instrumentation.

The MTA R&D effort generally falls into one of three categories: (i) providing support for the Muon Ionization Cooling Experiment (MICE); (ii) developing RF cavities filled with high-pressure gas as a way of circumventing the problem of RF breakdown; and (iii) developing more traditional, evacuated RF cavities capable of precisely studying and/or ameliorating the problem of RF breakdown in strong magnetic fields. Overviews of categories (i) and (ii) are provided here for context. The bulk of this paper focuses on category (iii).

Support for the Muon Ionization Cooling Experiment (MICE)

A demonstration of ionization cooling via MICE requires the assembly, commissioning, and operation of an RF cavity and coupling coil (RFCC) module: a large-diameter solenoid that surrounds four 201 MHz RF cavities [4]. The assembly of such a module (including RF couplers, tuners, cryogenic supply, instrumentation, etc.) is a significant effort.

A single-cavity module (SCM, Figure 2) is currently being commissioned in the MTA [5]. The experience gained during SCM assembly and systems integration efforts can be directly applied to the RFCC effort, expected to commence in the near future.

Ionization Cooling Channel Designs Employing High-pressure Gas-filled RF Cavities

Another R&D thrust in the MTA is the characterization of 805 MHz RF cavities loaded with high-pressure gas. As discussed above, RF breakdown in strong magnetic fields is an obstacle on the path to the full design of an ionization cooling channel. High-pressure hydrogen gas-filled RF (HPRF) cavities circumvent this problem. The dense gas suppresses RF breakdown via Paschen's Law, and additionally serves as an ionization cooling medium for muon beams.

* Work supported by the US Department of Energy Office of Science through the Muon Accelerator Program.

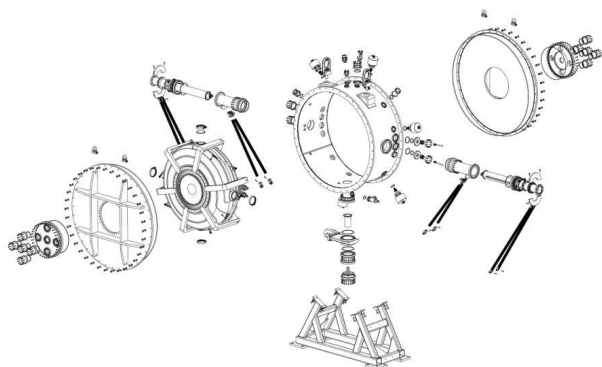

Figure 2: Exploded diagram of SCM showing outer vacuum vessel, cavity with tuners, input couplers, mechanical support, and vacuum and instrumentation feedthroughs.

Tests with an 805 MHz gas-filled cavity have demonstrated surface gradients as high as 65 MV/m in a 3 T solenoidal magnetic field [6]. Furthermore, this technology has been shown to work in the presence of intense, ionizing particle beams with no discernible B -field effects [7].

The HPRF approach to ionization cooling also allows RF cavities – and consequently, solenoidal magnets – to have a smaller diameter by means of dielectric loading [8]. An 805 MHz dielectric-loaded HPRF test cell is being fabricated now. Tests in the MTA are planned for Fall, 2014.

THE MODULAR CAVITY EXPERIMENTAL PROGRAM

In parallel with these other efforts, work continues on the characterization of RF breakdown in 805 MHz RF cavities under vacuum and in multi-Tesla magnetic fields. The goal here is to understand whether the problem of RF breakdown can be circumvented for evacuated RF cavities under strong magnetic fields and, if not, to determine the ultimate gradient limit on accelerating cavities in an ionization cooling channel. Recent measurements for the 805 MHz “All-Seasons” cavity show a maximum safe operating gradient of 25 MV/m in zero magnetic field, and of (or slightly above) 20 MV/m at magnetic fields between 0.25 and 5 Tesla [9]. Contrast this result with those presented in [2], in which the operating gradient fell and the RF breakdown probability increased monotonically with increasing magnetic field. An extensive analysis effort is now underway with the aims of (a) understanding the fundamental source of gradient limitation for this cavity geometry; and (b) understanding why this cavity displayed more stable behavior than others in the presence of strong magnetic fields. Similarly stable behavior was also observed recently in an 805 MHz pillbox cavity with gridded windows [10].

To better understand this behavior and to explore other questions related to RF breakdown in strong magnetic fields, an 805 MHz modular pillbox cavity was designed and built. Lawrence Berkeley National Laboratory was responsible for the RF design of the cavity and SLAC’s expertise in normal-conducting RF structures made that laboratory a

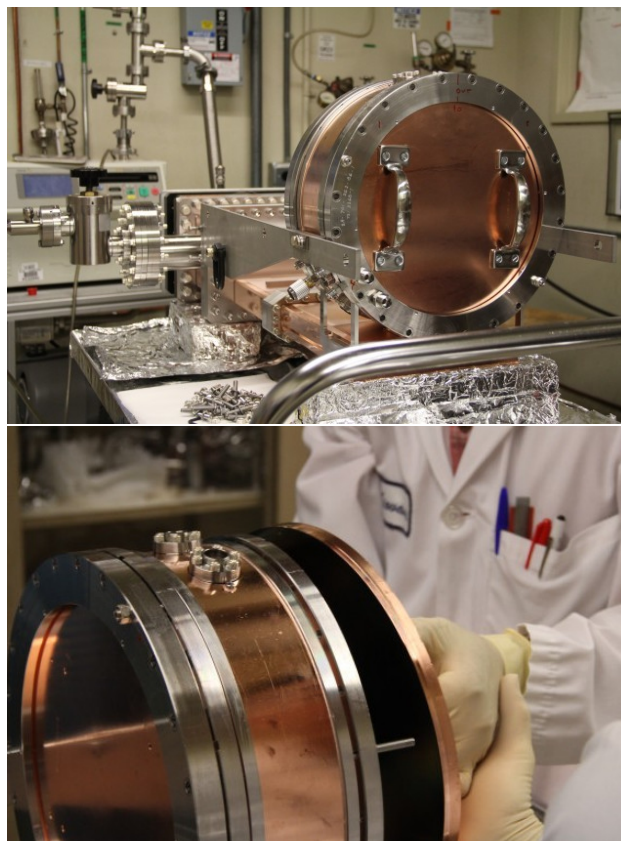

Figure 3: (Above) Modular cavity assembly. From left to right: RF window, WR-975 waveguide, vacuum ports and instrumentation, mechanical support and transition waveguide, cavity body. Note the stainless steel clamp ring, at the end plate perimeter, that fastens the end plate to the cavity body. (Below) Unmounting the cavity end plates. Once the clamp ring is removed, the end plates can be pulled off cleanly. Note the two mini-CF instrumentation ports at the top of the photo.

natural choice for the mechanical design and fabrication effort. The cavity is modular in that its end walls may be unmounted relatively easily, as shown in Figure 3. This drastically simplifies the inspection and characterization of breakdown damage. It also allows for the evaluation of materials other than copper (e.g. beryllium) as candidates to ameliorate the breakdown problem [11].

The modular cavity has a design frequency of 805.0 MHz and an unloaded $Q_0 \approx 25600$. The inner length is 10.44 cm, based on a $\pi/2$ phase advance for $v/c \approx 0.85$ muon beams. The inner radius is 14.2 cm. The cavity is magnetically coupled in the radial direction to a narrow feeder waveguide through a coupling iris, the design of which is discussed in more detail below. The narrow feeder waveguide is necessary in order to fit the entire cavity assembly inside the 44 cm warm bore diameter of the MTA solenoid. This waveguide transitions to a standard WR-975 waveguide outside the solenoid and terminates in a ceramic WR-975 RF window. Vacuum pumping ports are also situated outside the solenoid. There are six mini-CF instrumentation ports situated around

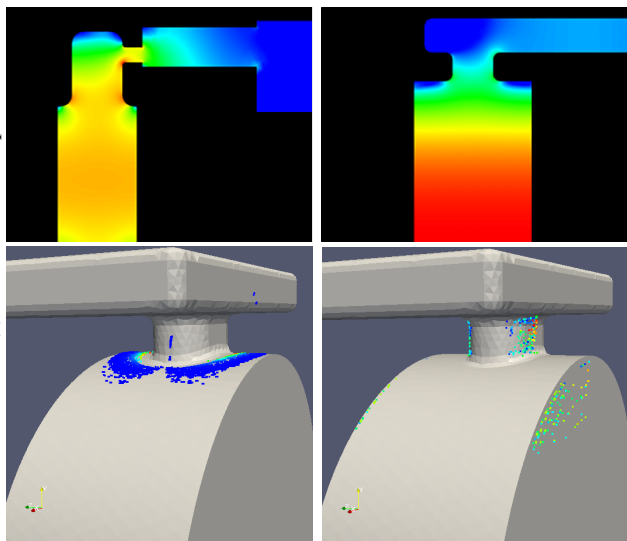

Figure 4: Some ACE3P simulation results. (Top left) 805 MHz pillbox cavity E -field. Red represents strong E -fields, blue represents weak. (Top right) Modular cavity E -field, with highest field on longitudinal axis. (Bottom left) Resonant multipacting trajectories in modular cavity at $B = 0$ T. (Bottom right) Trajectories for $B = 3$ T.

the cavity equator. These ports can be fitted with RF pickups and optical inspection instrumentation interchangeably. Many of these features are visible in Figure 3. The cavity interior was coated with a thin TiN film to suppress secondary electron yield during multipacting.

ACE3P, SLAC's parallel, finite element RF simulation code suite, was used extensively in the RF and mechanical design of the modular cavity [12]. Using that code, the input coupler iris geometry was optimized to minimize multipacting both with and without a solenoidal magnetic field present. The iris was also designed to minimize geometric surface electric field enhancement. In order to reduce systematic error in the assessment of RF breakdown events, it is desirable to have these events concentrated near the longitudinal axis of the cavity. The surface electric field strength on the modular cavity's longitudinal axis is therefore designed to be more than five times stronger than the surface electric field on the coupling iris. See Figure 4. ACE3P was also used to determine the optimal placement of water cooling lines in the cavity body.

STATUS AND FUTURE PLANS

The modular cavity will be delivered to Fermilab during the summer of 2014. Final testing is in progress now, including vacuum and water leak checking and RF characterization.

The modular cavity will be used for several tests in the coming year. First, the maximum safe operating gradient¹

¹ The maximum safe operating gradient is defined as the maximum accelerating gradient achievable with a spark rate less than 10^{-5} . This is based on a projected acceptable cavity trip rate in an ionization cooling channel.

will be established for $B = 0$ T and for $B = 3$ T using copper end plates coated with TiN. This measurement must be conducted on several sets of identical end plates, as we expect the cavity surface to change over time from pulsed RF heating and breakdown arcs. A cavity conditioned at $B = 0$ T may therefore behave differently than one conditioned at $B = 3$ T. Once the safe operating gradient for a given B -field is established, long experimental runs with many consecutive RF pulses will determine the "lifetime" of freshly resurfaced end plates. The goal here is to determine the rate at which pulsed heating and RF breakdown change the behavior of a clean cavity surface in a strong magnetic field. Subsequently, runs under similar conditions will be made with beryllium end plates in order to evaluate the breakdown model proposed in [11] and to gain critical experimental insight into the operation of RF cavities with beryllium walls, as discussed in [1]. Further work examining the effects of different end wall materials, cavity body lengths, frequency scaling, etc. will also be performed contingent on available time and resources.

REFERENCES

- [1] D. Stratakis, "Theoretical Framework to Predict Efficiency of Ionization Cooling Lattices", these proceedings, TUPME021, IPAC2014, Dresden, Germany.
- [2] R. Palmer *et al.*, "RF Breakdown With External Magnetic Fields in 201 and 805 MHz Cavities", PRST-AB **12**, 031002 (2009).
- [3] M. Jana *et al.*, "Investigation of Breakdown Induced Surface Damage on 805 MHz Pillbox Cavity Interior Surfaces", Proc. NA-PAC 2013, FERMILAB-CONF-13-410-APC.
- [4] J. Nugent, V. Palladino, "The Physics Programme of next MICE Step IV", these proceedings, TUPME010, IPAC2014, Dresden, Germany.
- [5] Y. Torun *et al.*, "Installation and Commissioning of the MICE Single-Cavity Module", these proceedings, THPRI067, IPAC2014, Dresden, Germany.
- [6] P. Hanlet *et al.*, "High pressure RF cavities in magnetic fields", Proc. EPAC 2006, Edinburgh, Scotland. TUPCH147.
- [7] M. Chung *et al.*, "Pressurized H₂ RF Cavities in Ionizing Beams and Magnetic Fields", Phys. Rev. Lett. **111**, 184802 (2013).
- [8] M. Popovic *et al.*, "Dielectric Loaded RF Cavities for Muon Facilities", Proc. IPAC 2010, Kyoto, Japan. THPEA047.
- [9] Y. Torun *et al.*, "Extended RF Testing of the 805 MHz Pillbox 'All-Season' Cavity for Muon Cooling", these proceedings, THPRI068, IPAC2014, Dresden, Germany.
- [10] A. Moretti *et al.*, "Tube-Grid Windows for Pillbox Cavities", these proceedings, THPRI069, IPAC2014, Dresden, Germany.
- [11] D. Stratakis, J.C. Gallardo, and R.B. Palmer, Nucl. Inst. Meth. A **620** (2010), 147-154.
- [12] K. Ko *et al.*, "Advances in parallel electromagnetic codes for accelerator science and development," LINAC2010, Tsukuba, Japan. SLAC-PUB-14349.