

Mapping Developments at Diamond

Rob Walton

22nd October, ICALEPCS 2015, Melbourne



Scaling software at Diamond

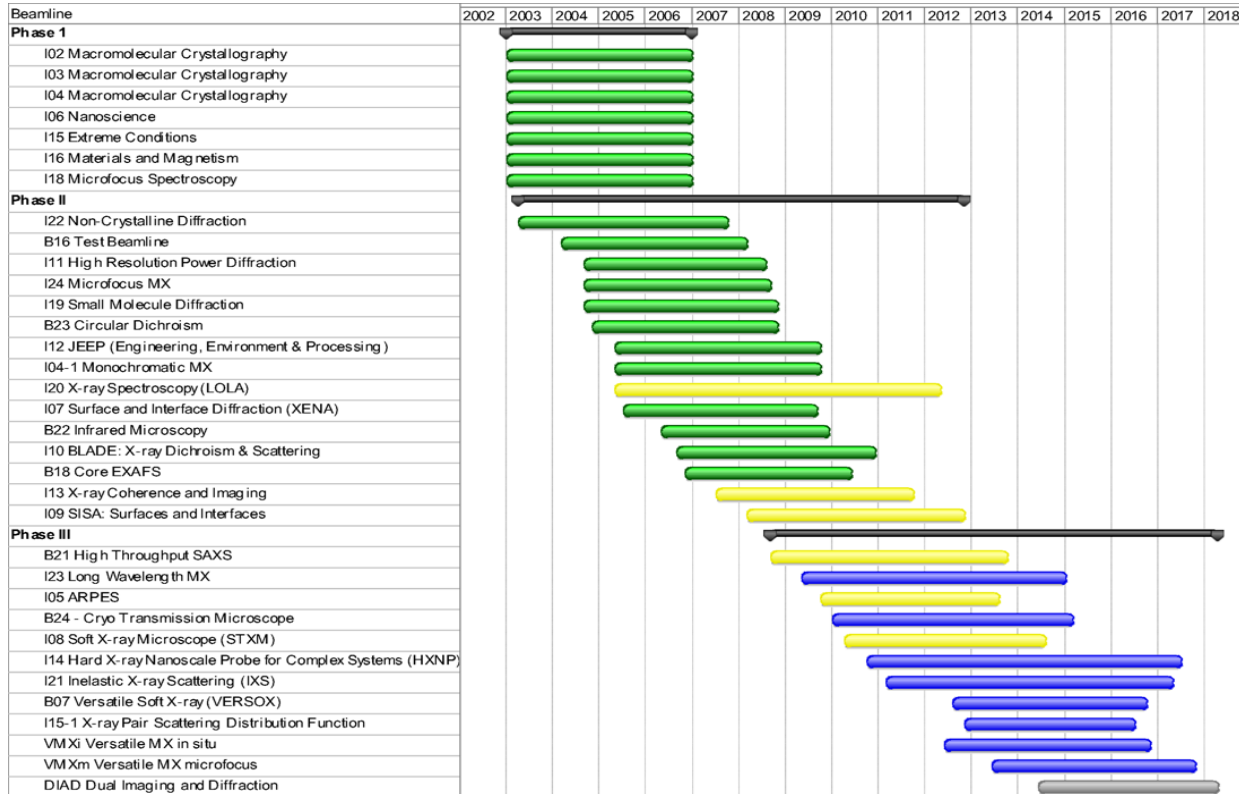

- 31 beamlines
- 43+ end stations
- Ever higher demands of software
- Focused on scaling
 - Deploy
 - Automation
 - **Mapping**

Mapping

- Many beamlines perform mapping experiments
- Move sample under focused x-rays
- Continuous or trajectory motion (a.k.a. fly scan)
- Interactions include e.g.:
 - **Fluorescence (XRF)**
 - Absorption
 - Scattering
 - Diffraction
 - **Electron emission (ARPES)**
- Process
 - Reduce data to create a map (image)
- Visualization
 - Show map of reduced data
 - Click to see raw or detailed data

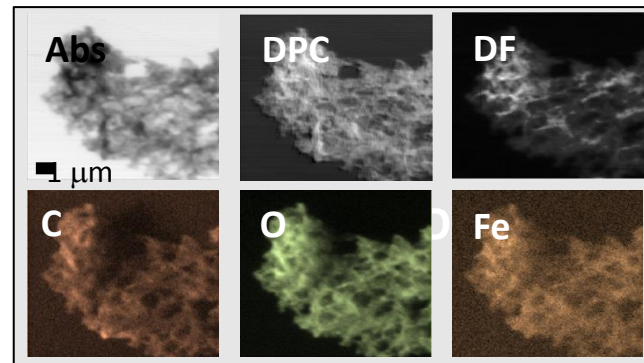
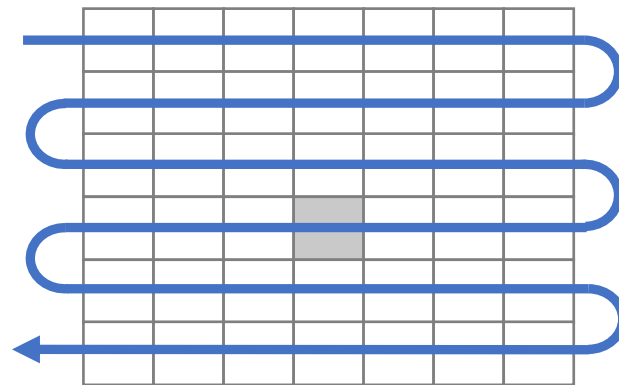

Fluorescence

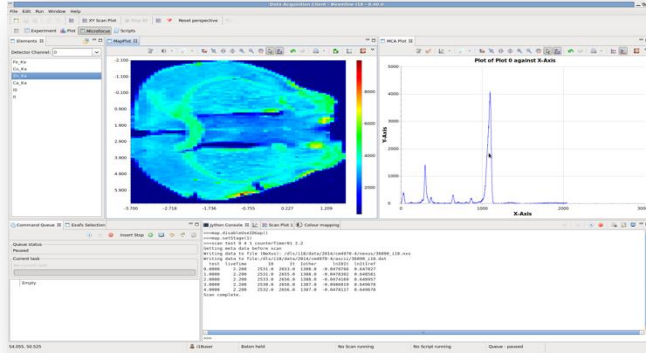
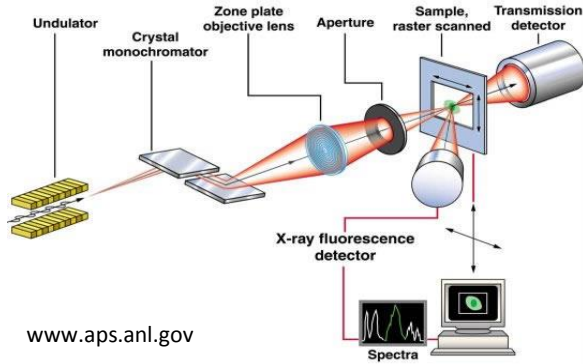

Map of zinc content, detail is spectrum

Nano-ARPES

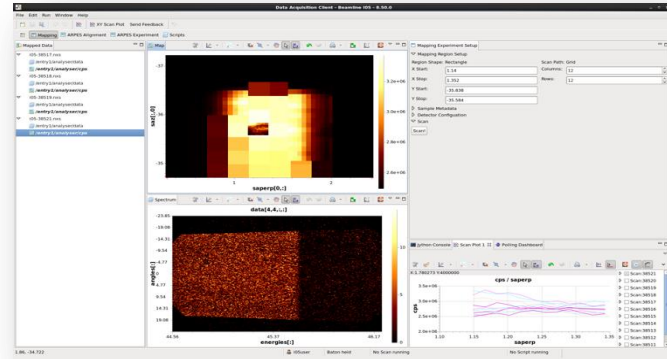
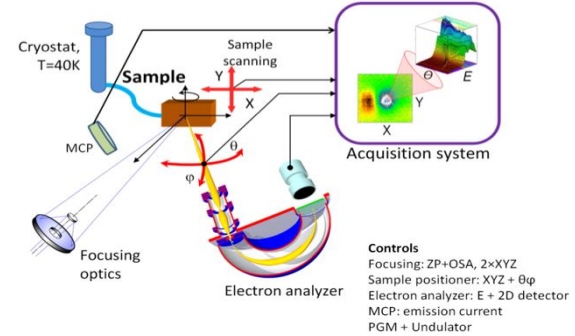

Map of measure of electron momenta, detail is energy v's angle

Hardware

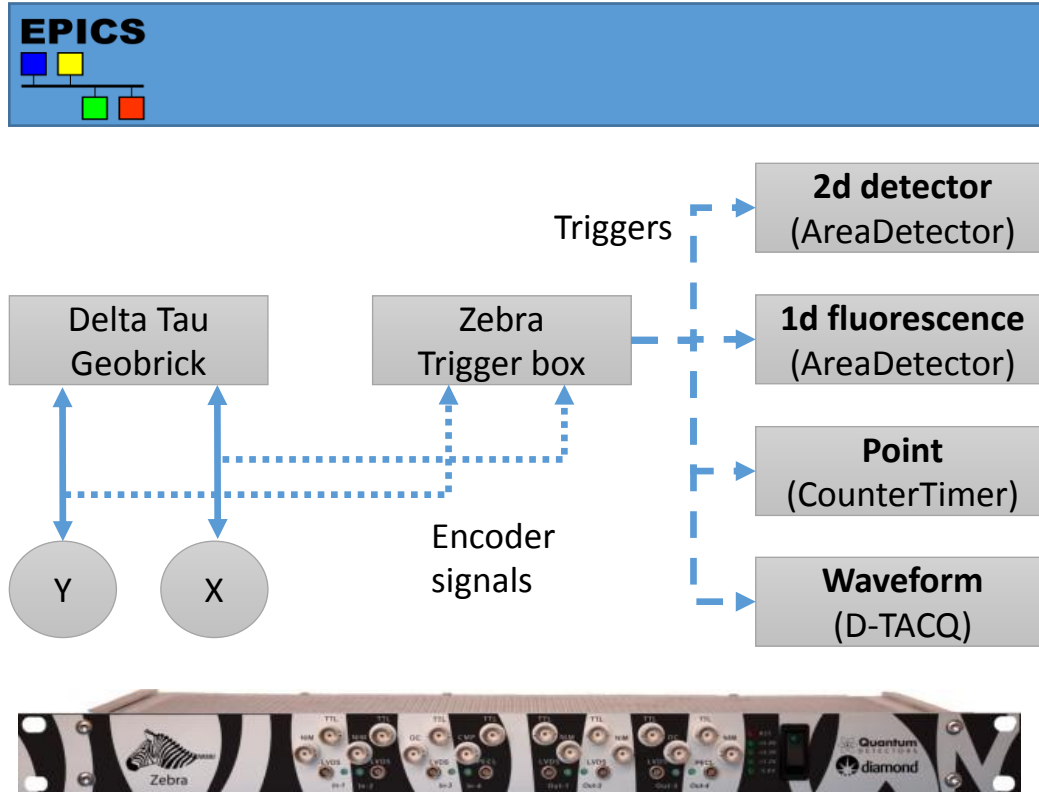

Diamond's "Mapping project"

- Create generic solutions
- Target beamlines
 - 5 diverse to start
 - More to follow MX (7), Other (5+)
- Scope:
 - User work flow
 - Streamlined data flow
 - Generic continuous scanning framework
 - Standardise processing and visualisation
 - Reusable GUI components
- Cuts across many systems and groups

	XRF	XAS	Diffraction	ARPES	SAXS
I05-1 Nano-ARPES				■	
I08 Scanning x-ray microscopy	■	■	■		
I13 X-Ray Imaging & Coherence			■		
I14 Hard X-ray nanoprobe	■	■	■		■
I18 Microfocus Spectroscopy	■	■	■		

Initial target beamlines

User work flow

- Interactively explore surface
 - Take visual image
 - Perform scan, selecting
 - Detectors
 - Parameters
 - Region, line or point
 - Process to create map or other data
 - Add to history

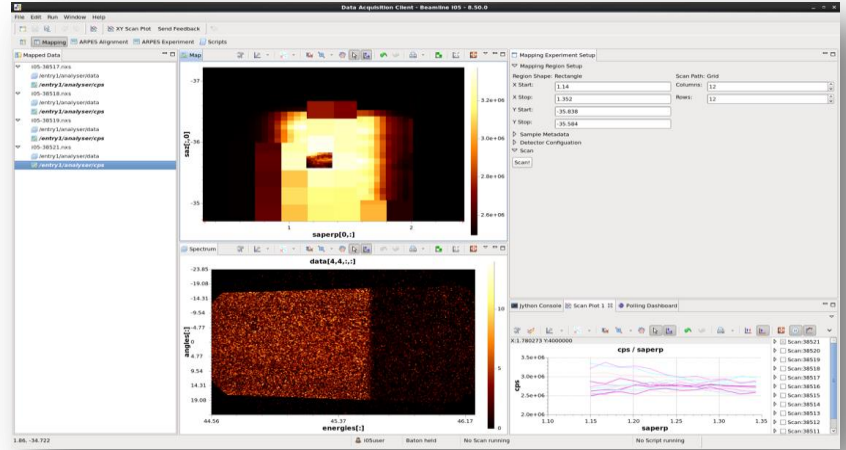

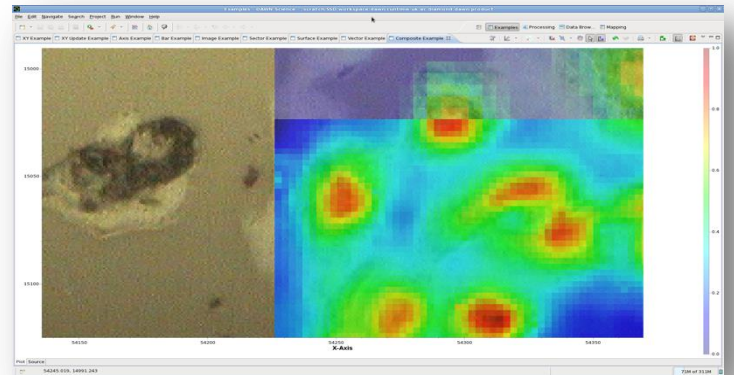

(Prototype RCP interface)





Streamlined data flow

- Committed to NeXus
 - Multidimensional
 - Multimodal (multiple techniques)
 - Geometry
 - Metadata (e.g. sample environment)
 - = Great for pipelined analysis (descriptive)
- Backed by HDF5
 - Combatable with centralized file storage
 - (small files load Lustre & GPFS metadata server)
 - Detectors write data
- But cannot be read as written
 - **HDF SWMR to the rescue**
 - Single **W**rite **M**ultiple **R**ead
 - HDF5 1.10 Spring 2016 (beta available)

processed.nx

Reduction A	
Reduction B	
Raw	

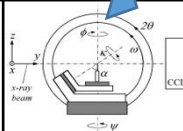
scan.nx

Geometry	
Metadata	
X position	
Y position	
Image det.	
Spectra det.	

zebra.h5

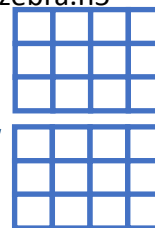
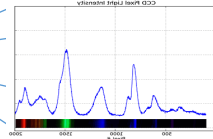
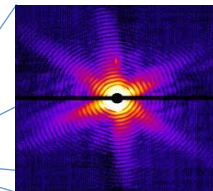

image.h5



spec.h5



Components

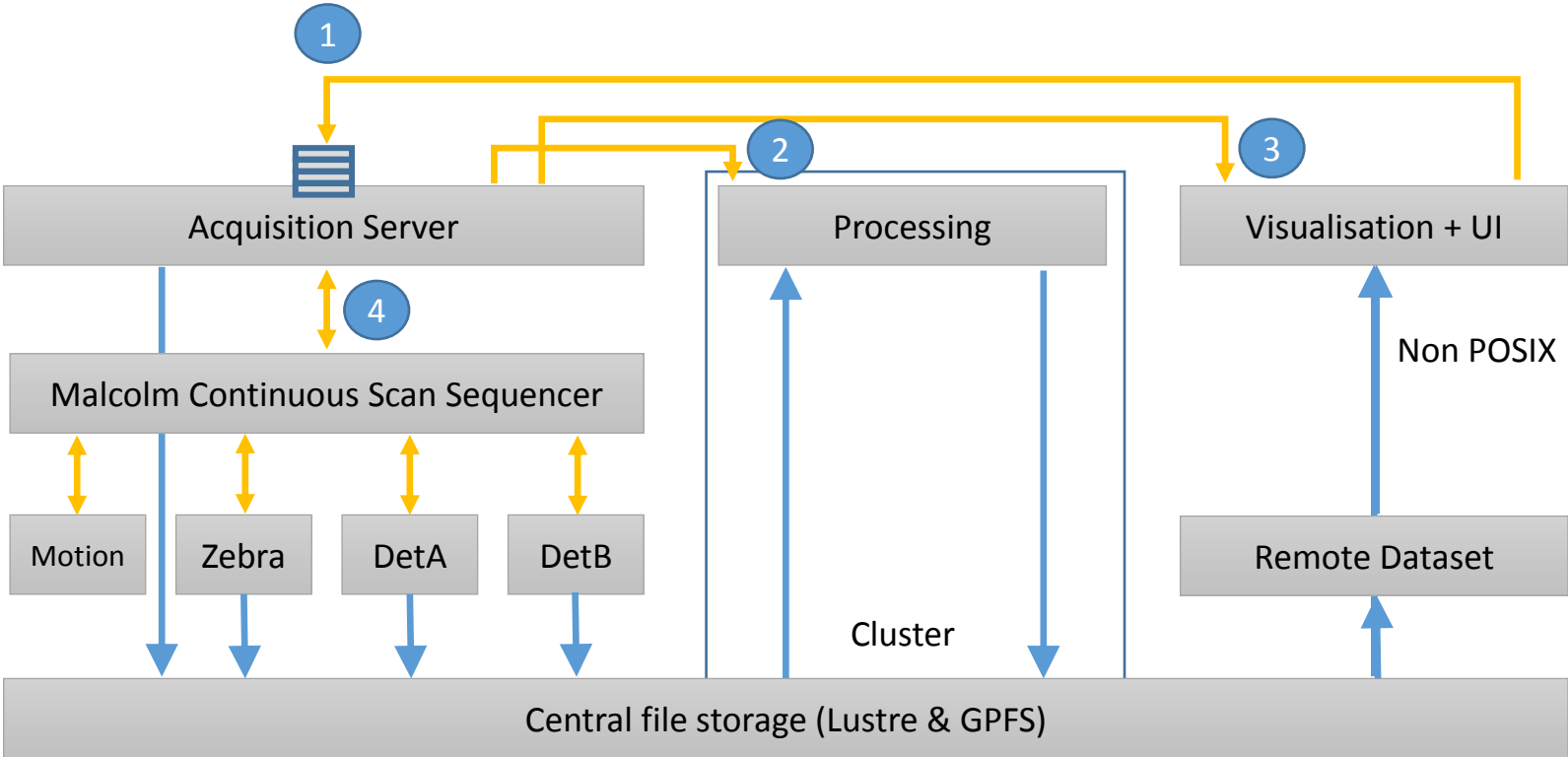

Access to all data live

- SWMR
 - Single path for data
- Same processing used live and after a collection
 - DAWN analysis pipeline
 - Calibrated powder diffraction
 - ARPES analysis
 - Tomography reconstruction
 - ... with access to cluster
- Same visualisation used live and after a collection
 - DAWN (dawnsci.org)

DAWN Analysis Pipeline

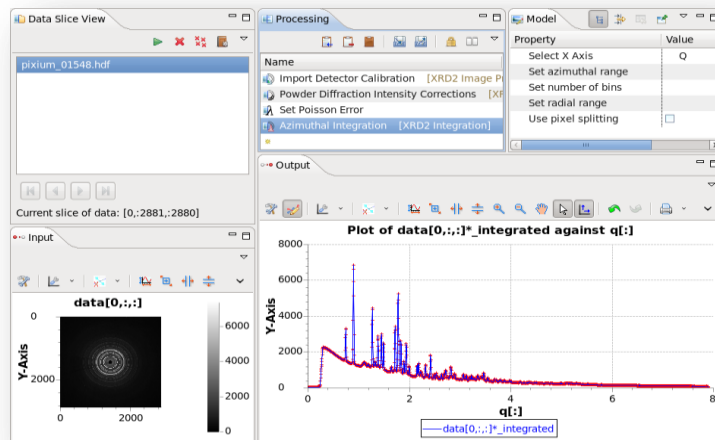

DAWN Hyperspectral viewer

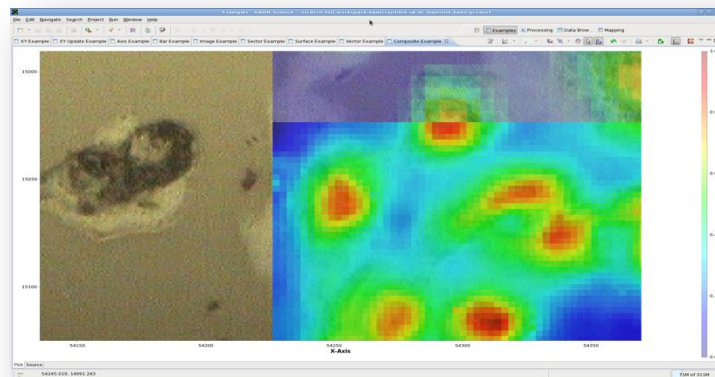

AreaDetector & Zebra SWMR enhancements

- HDF writing upgraded:
 - write HDF SWMR
 - write multidimensional data
 - Fill dataset in arbitrary order matching beam's path across surface
- E.g. Bi-directional raster scan
 - 2d (scan) + 2d (detector) = 4d
 - Snake path

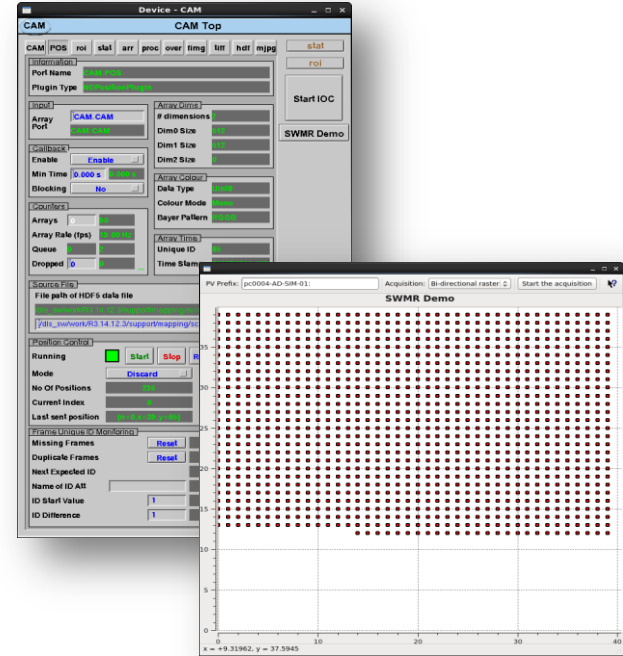
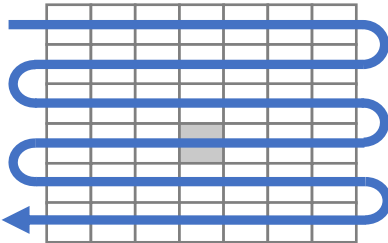

Epics AreaDetector writing bi-directional data during a raster scan using new plugin accessed by HDF plugins

New Malcolm EPICS service

- API for a generic continuous scanning framework
- Malcolm in the middle between acquisition server and EPICS
- Configure-Run state machine
 - `config()`, `run()`, `pause()`, `abort()`, `reset()`
- Nestable
- Currently:
 - Python server with JSON over websocket or zeroMQ
 - Java declarative OSGI service
 - Prototyping nano-ARPES stage and electron analyser
- Future:
 - pvData over pvAccess
 - C++ port for AreaDetector
 - More scans types
 - More detector combinations

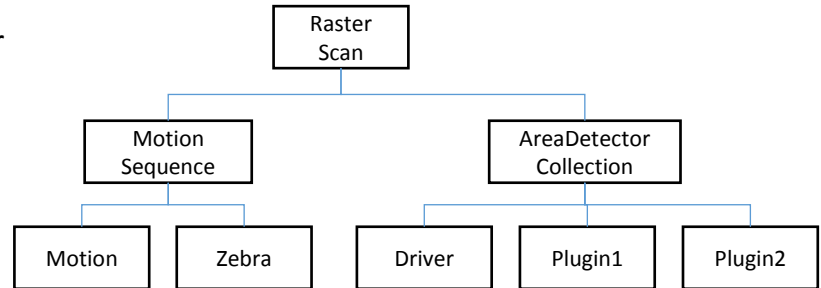
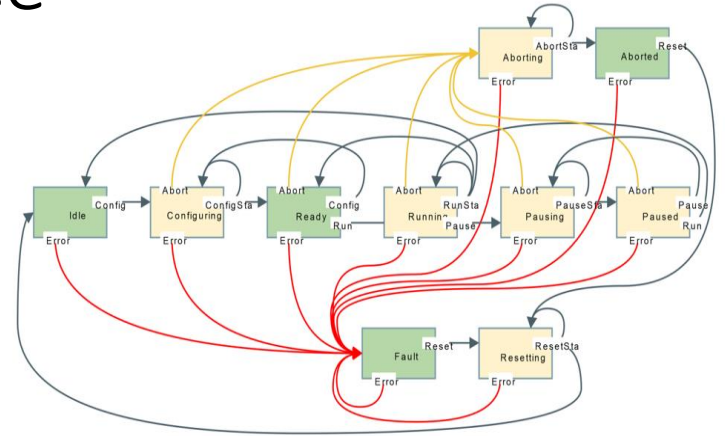

User interface views

- Eclipse RCP
- Eclipse IDatasets
 - From NeXus file
 - From Remote Dataset service
- Light to maintain
 - Auto generated parameter editors
 - Compose for different beamlines
 - Future: Adapt to server?
- Build views into
 - GDA client
 - DAWN
 - Anything RCP

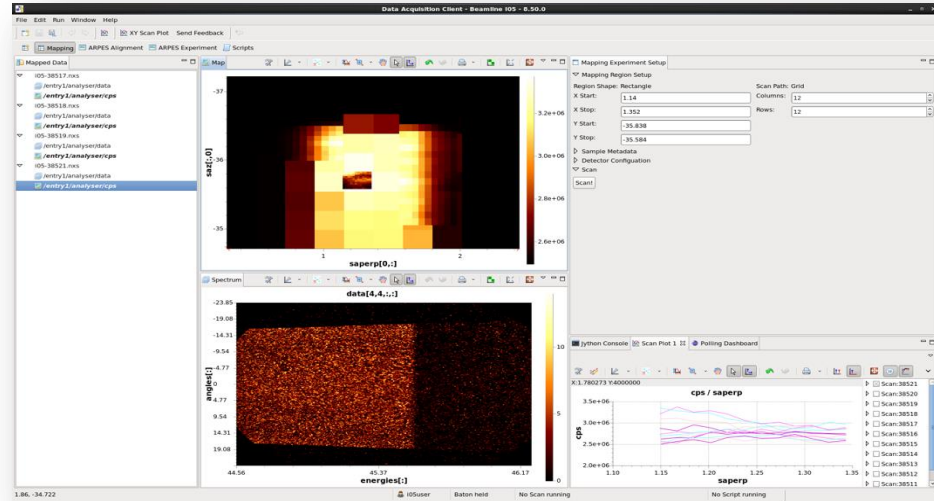

Acquisition server

- Acquisition Server contains:
 - NeXus Writer service
 - Malcolm OSGI service
 - Remote Dataset service for client
- JMS Broker (Active MQ)
 - Server to DAWN Pipeline analysis
 - Server to client
- Build acquisition server into
 - GDA server (splitting up)
 - Decoupled OSGI declarative services
 - Anything Java
 - Anything RCP (OSGI)

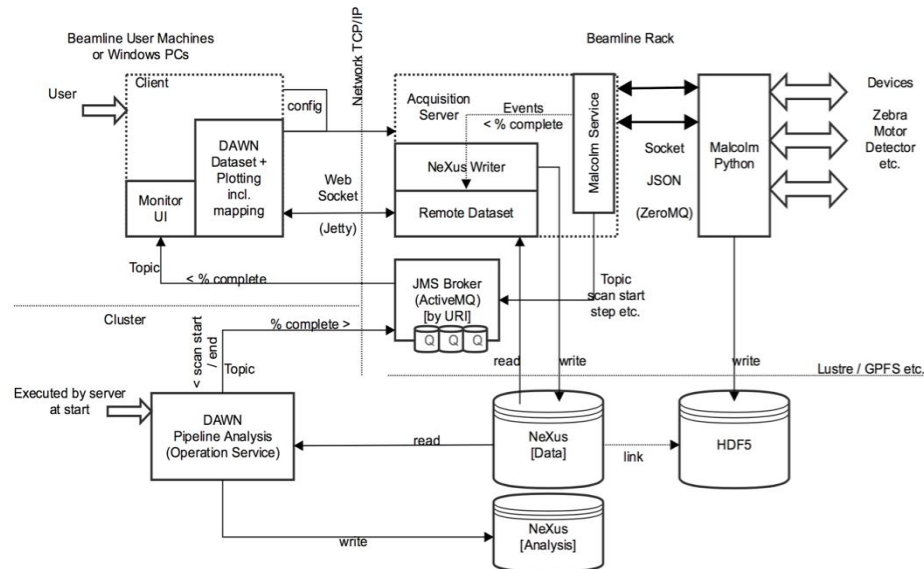

Status

- 6-8 months into project
- Tested on one beamline
- Deploying next Spring and Summer to 3 more
- 2 years to 'complete'

Conclusion

- Focused on 5 beamlines with more to follow
- We like NeXus HDF5 and with SWMR we looking forward to seeing out data like the good old days!
- Malcolm providing a promising API for continuous scanning
- Breaking down GDA software
- Line scans are just $1 \times N$ mapping scans

Acknowledgements

Analysis



Alun
Ashton



Mark
Basham

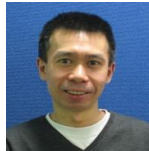

Peter
Chang



Jacob
Filik

Controls



Nick
Rees



Ulrik
Pedersen



Tom
Cobb

Science



Andy
Dent



Paul
Quinn

Acquisition



Matt
Gerring



James
Mudd



Charles
Mita



Colin
Palmer



Silvia
Da Graca
Ramos