

TIMING SYSTEM STATUS AND DEVELOPMENT

MPS flow of SR1 and SR3 general block diagram.

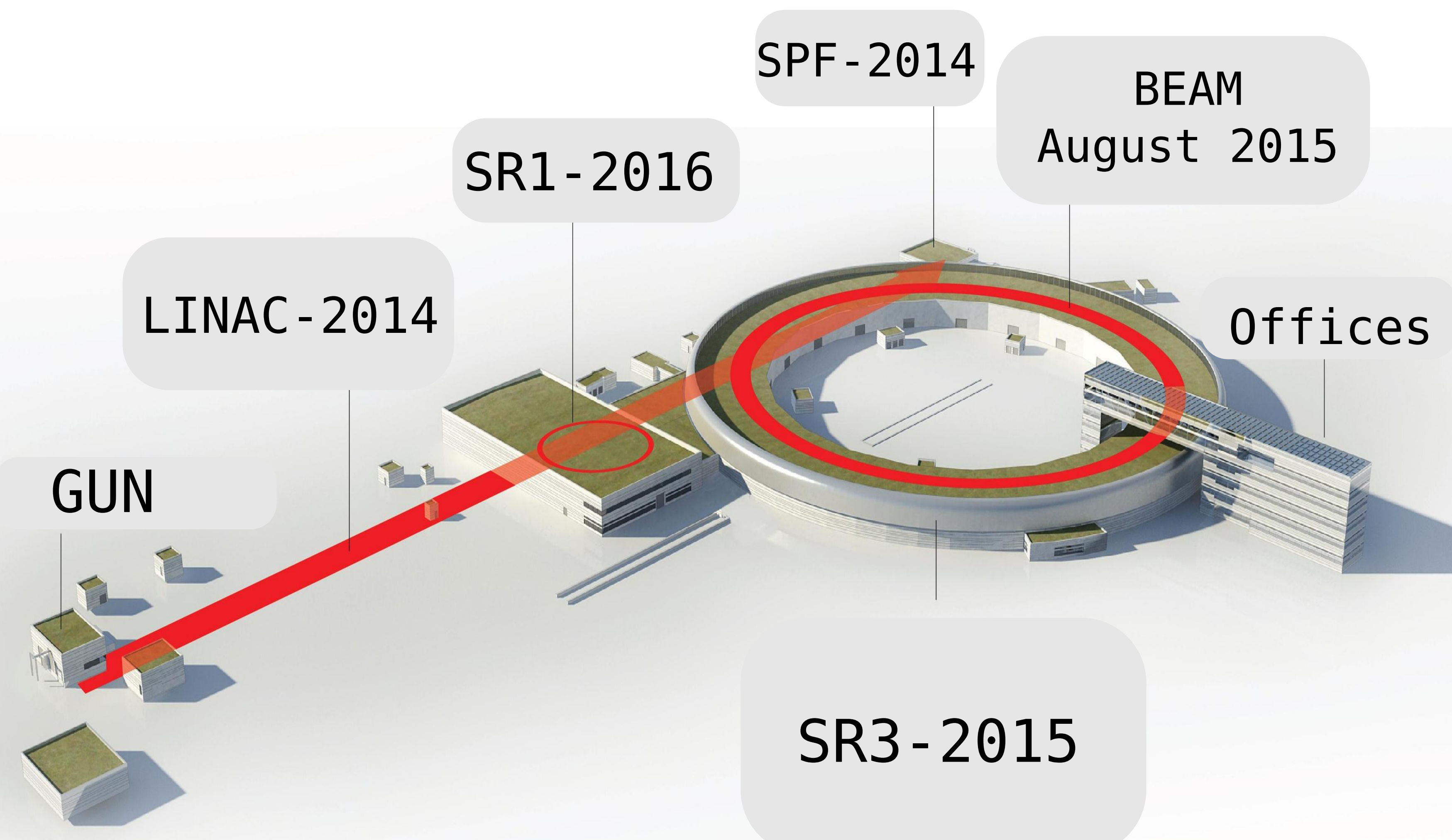

LINAC Trigger Selector

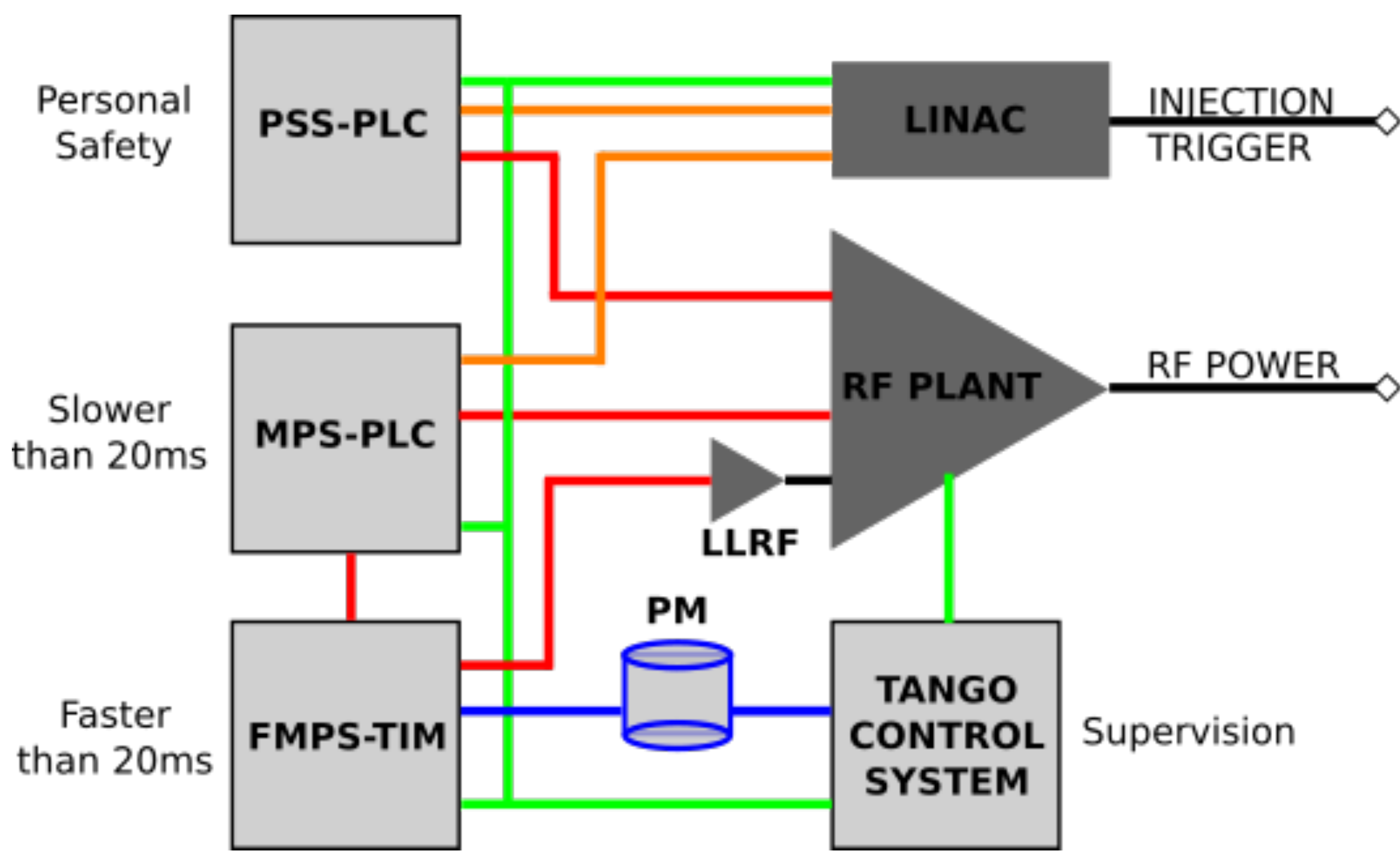
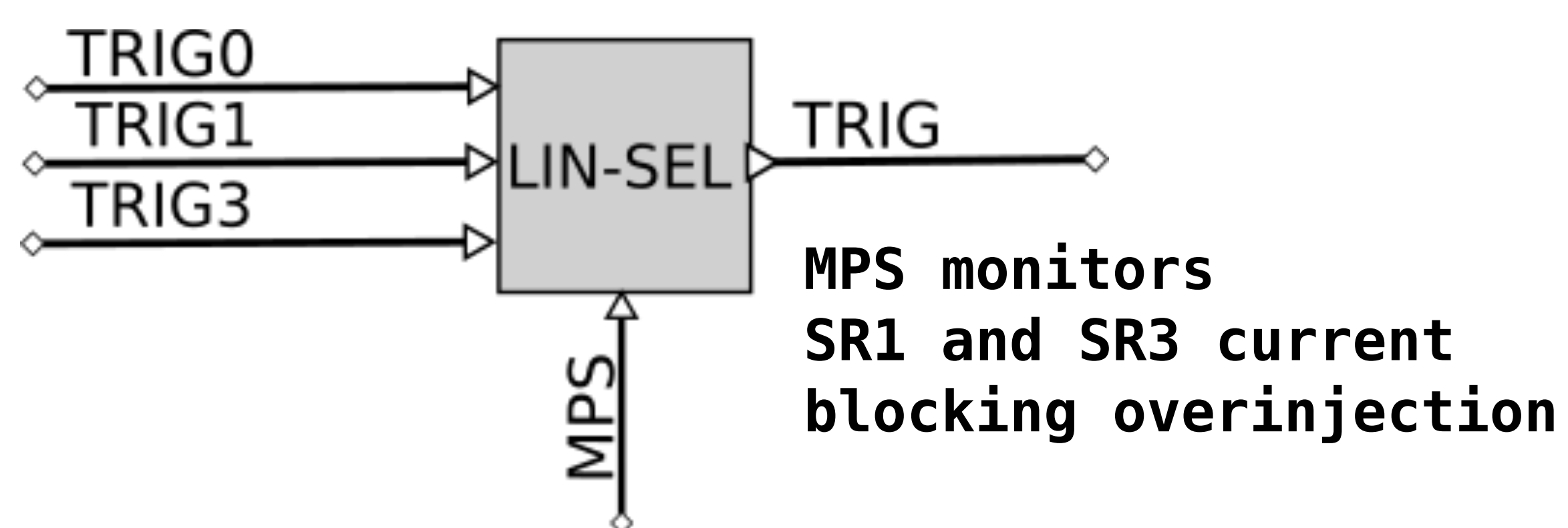

LIN and SPF – TRIG0 (3GHz, 77MHz, 50Hz)
 SR1 – TRIG1 (100MHz, 3.12MHz, 50Hz)
 SR3 – TRIG3 (100MHz, 568kHz, 50Hz)

MAX IV will work in 4 different modes:
 LINAC 3GeV (LIN)
 LINAC 3GeV + Short Pulse Facility (SPF)
 LINAC 3GeV + Storage Ring 1.5GeV (SR1)
 LINAC 3GeV + Storage Ring 3GeV (SR3)

LIN and SPF are rated for 100Hz injection whereas SR1 and SR3 for 10Hz.

Future LINAC trigger upgrade

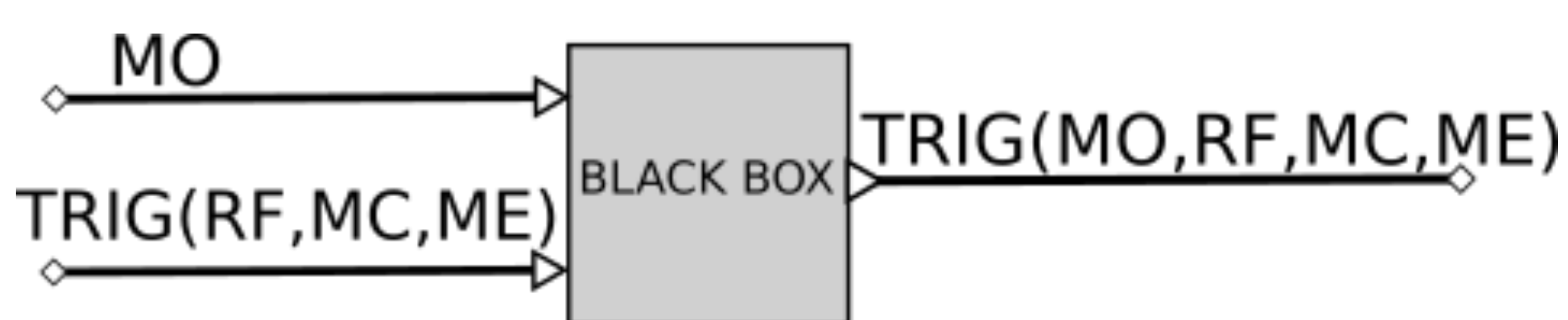

LINAC chopper selection of 3x330ps electron bunches

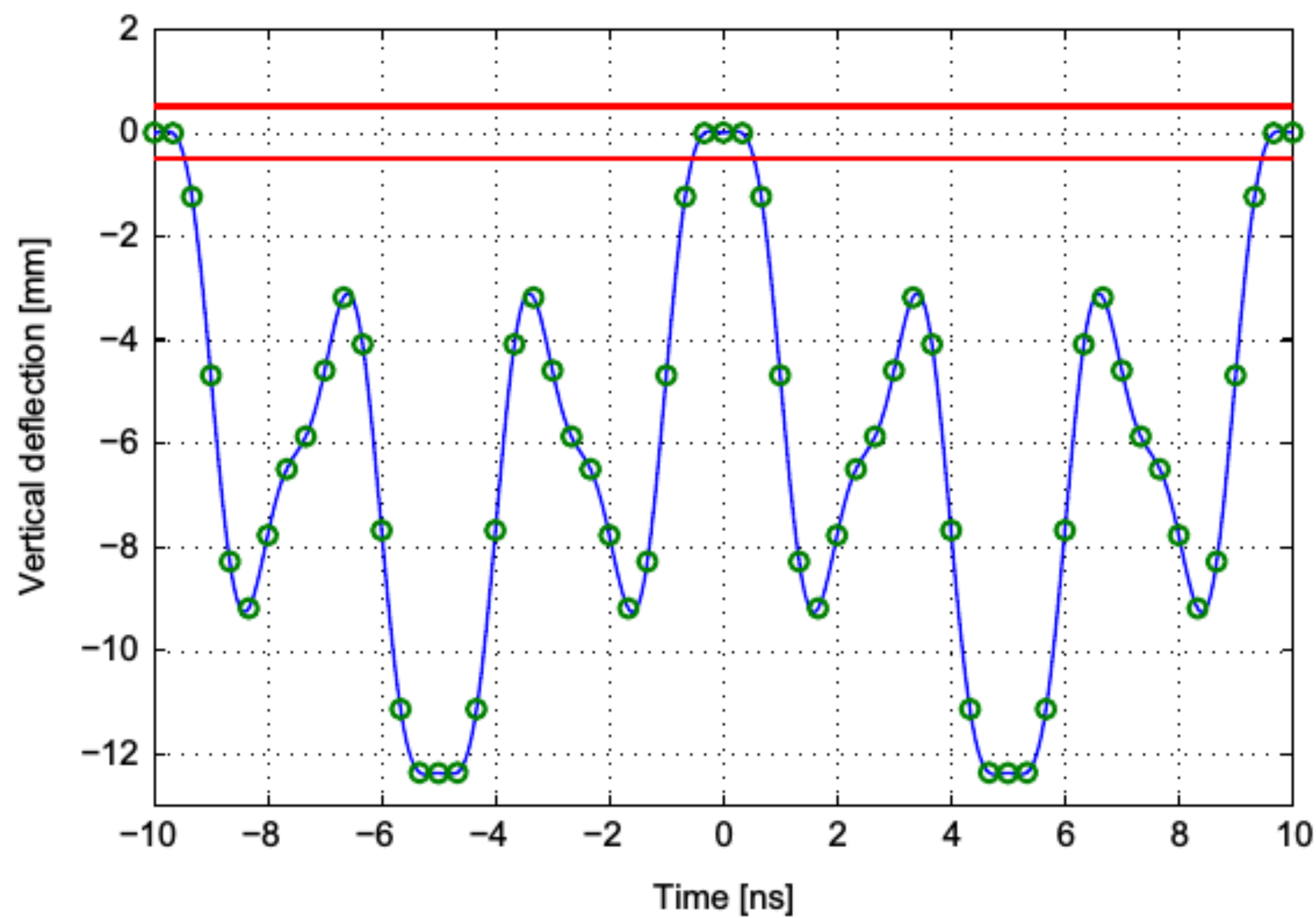

TRIG(RF,MC,ME) = SR injection from 2x up to 3.5x bunch per SR bucket

TRIG(MO,RF,MC,ME) = SR injection exactly 3x bunch per SR bucket

MAX IV state grid presenting TANGO "States"

3 GeV ring											
	VAC	VACValves	MAG	RF	TIM	DIA	DIA/BPM	DIA/Inserts	WAT		
301	ON	OPEN	ON	FAULT	ON	ON	NA	ON	ON	ON	301
302	ON	MOVING	ON		ON	ON	NA		ON	ON	302
303	ON	OPEN	ON		ON	ON	NA		ON	ON	303
304	ON	OPEN	ON		ON	ON	NA		ON	ON	304
305	ON	OPEN	ON		ON	ON	NA		ON	ON	305
306	ON	OPEN	ON		ON	ON	NA		ON	ON	306
307	ON	OPEN	ON		ON	ON	NA		ON	ON	307
308	ON	OPEN	ON		ON	ON	NA		ON	ON	308
309	ON	OPEN	ON		ON	ON	NA		ON	ON	309
310	ON	OPEN	ON		ON	ON	NA		ON	ON	310
311	ON	OPEN	ON		ON	ON	NA		ON	ON	311
312	ON	OPEN	ON		ON	ON	NA		ON	ON	312
313	ON	OPEN	ON		UNKNOWN	ON	NA		ON	ON	313
314	ON	OPEN	ON		ON	ON	NA		ON	ON	314
315	ON	OPEN	ON		ON	ON	NA		ON	ON	315
316	ON	OPEN	ON		ON	ON	NA		UNKNOWN	UNKNOWN	316
317	ON	OPEN	ON	RUNNING	ON	ON	NA		UNKNOWN	UNKNOWN	317
318	ON	OPEN	ON		ON	ON	NA		ON	ON	318
319	ON	OPEN	ON	RUNNING	ON	ON	NA		ON	ON	319
320	ON	OPEN	ON		ON	ON	NA		ON	ON	320
PLC	RUNNING		RUNNING						RUNNING		PLC
Alarm			ON								Alarm
Global			ON				NA				Global

TIM and DIA/BPM columns present the timing system integration

3 GeV ring > TIM,Global			
EVG	EV	MO	SEL
01	RUNNING	ON	ON

Sub-field of "Global TIM"