

Timing Systems for ATNF Telescopes

S A Hoyle (CASS), P Mirtschin (CASS)

CSIRO ASTRONOMY AND SPACE SCIENCE
www.csiro.au



Radio Telescopes require precise time and timing signals for accurate telescope pointing, synchronisation of signal processing instrumentation and offline manipulation of observation data.

Introduction

Australia Telescope National Facility observatory sites include the Parkes 64m single dish, the Compact Array and the Australian Square Kilometre Array Pathfinder (under construction and early commissioning).

Observations are made with the Compact Array and Parkes 64m telescopes both separately and together to form the Long Baseline Array. Occasionally, the array is extended further with radio telescopes in Tasmania and New Zealand. The technique of using widely separated telescopes in concert provides increased resolution and hence greater detail in the final astronomical images and is known as Very Long Baseline Interferometry (VLBI).

Timing and synchronisation is required for instruments within a single antenna, between antenna elements of an array and between widely separated observatory sites.

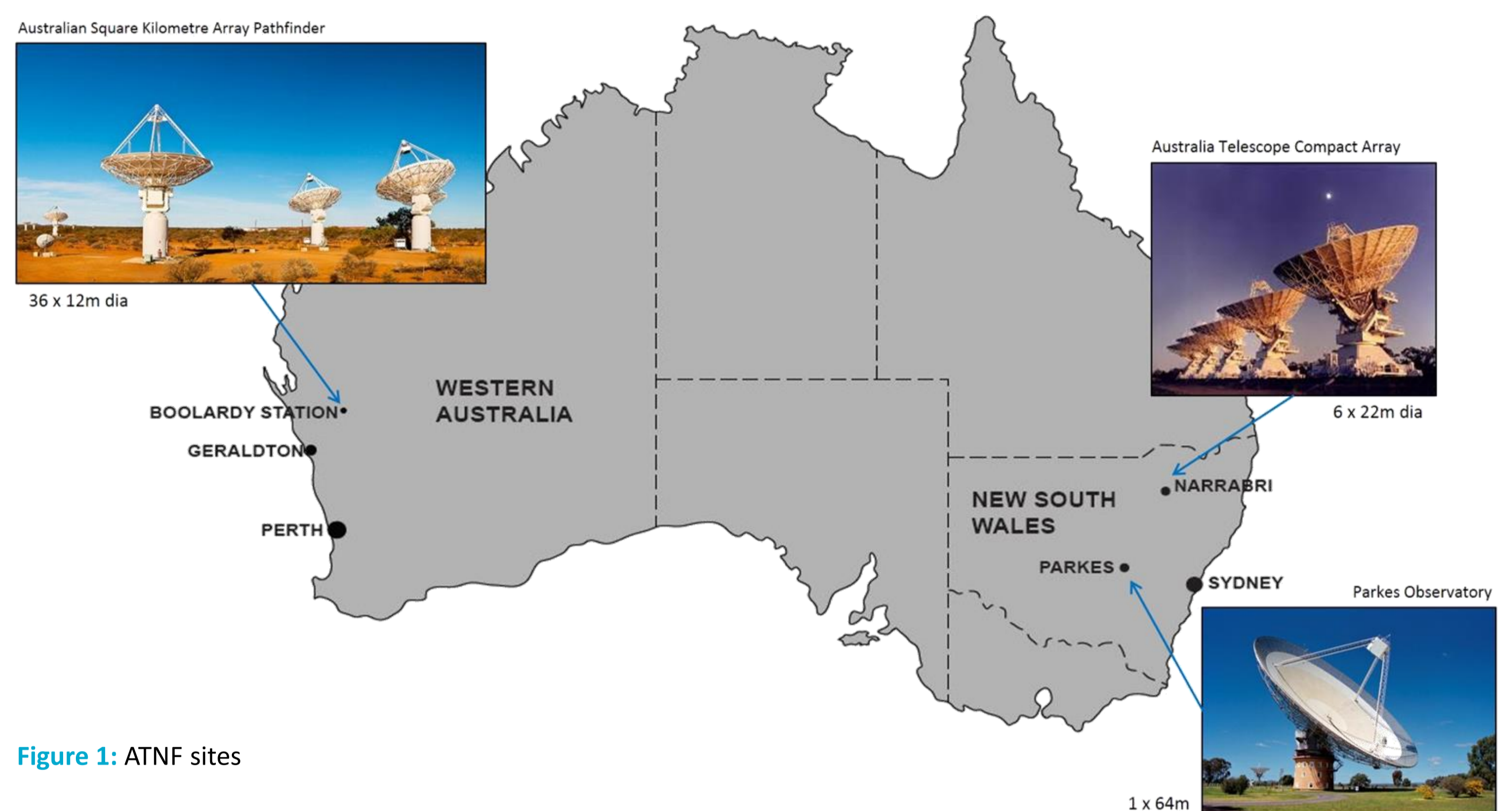

Figure 1: ATNF sites

Application of Timing (Fig. 2)

At each antenna, local oscillators (LOs) are required to 'tune' the receiver and for further stages of down conversion prior to digital sampling. All LOs are phase-locked to a highly stable central reference oscillator to maintain constant phase and phase coherence. Phase jitter reduces the quality of the final astronomical image and lack of phase coherence results in reduced overall sensitivity.

The 'Integration Cycle' is a timing waveform input to the Sampler/Digitiser and Correlator. To attain sufficient dynamic range, the correlator accumulates the correlated input data streams for a period of typically 5 or 10 seconds, prior to transformation to the frequency domain. At each Sampler, a 'Start of Integration' timing mark is included in the observation data streams for precise alignment at the Correlator.

The 'Calibration Cycle' waveform modulates a noise source of known power at the input to the receiver in order to determine the overall system gain and hence the true flux of the celestial source.

Precise Universal Coordinated Time (UTC) supplied to the Antenna Control Computer together with the geographic coordinates of the observatory and the Right Ascension / Declination of the source enables it to determine the azimuth and elevation antenna pointing coordinates and synchronise a software control loop to execute a scanning or tracking trajectory.

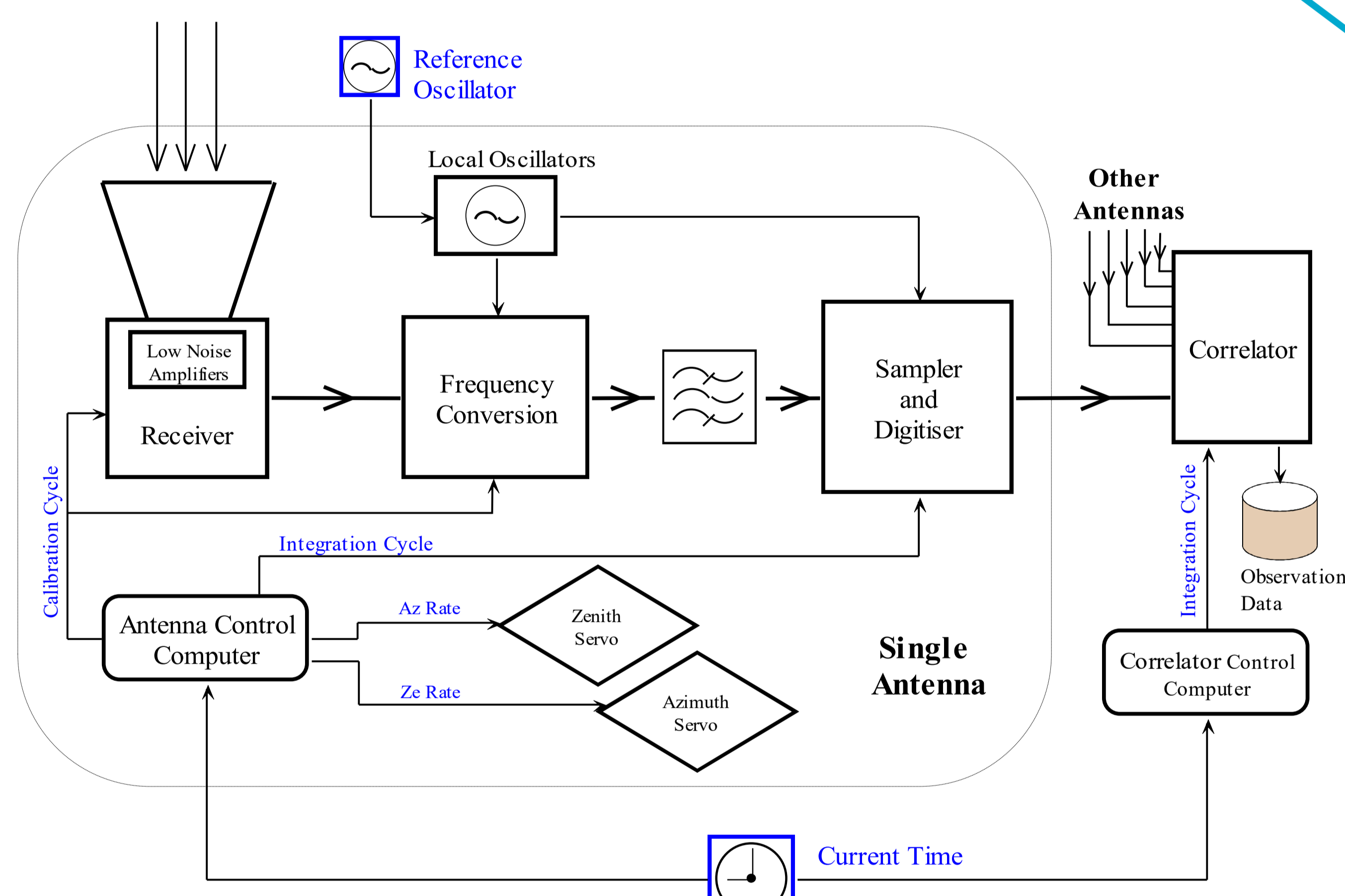

Figure 2: Radio Telescope basic instrumentation

Basic architecture (Fig. 3)

A central Hydrogen Maser / Reference Oscillator provides the highly stable reference frequency, (typically 5 MHz), to phase-lock the antenna local oscillators and an 'ATNF Distributed Clock' (ATDC). The purpose of the ATDC is to generate and distribute time signals to time dependent equipment throughout an observatory site. Time information is encoded in a bit stream, the 'Clock Frame', and transmitted once per millisecond over fibre optic cable or balanced copper pairs commonly referred to as the 'Clock Bus'. The ATDC divides the input reference oscillator frequency in stages to produce a one pulse per second (1pps) output. An external 1pps from a GPS Receiver provides a reference 'tick' input to the ATDC for comparison with its own 1pps. The difference, the 'Tick Phase', provides a fine-grain measure of the accuracy of the clock. We can 'slide the clock' in 200 nanosecond steps to minimise the tick phase.

The GPS 1pps is the common timing reference between sites and the Reference Oscillator the source of precision timing at each site.

An 'ATNF Event Generator' (ATEG) receives and decodes the Clock Frame data. An ATEG can be pre-programmed to change the state of any of its sixteen digital output lines at an absolute time with microsecond precision. Through software control it can generate pulse trains and single events with high precision and stability.

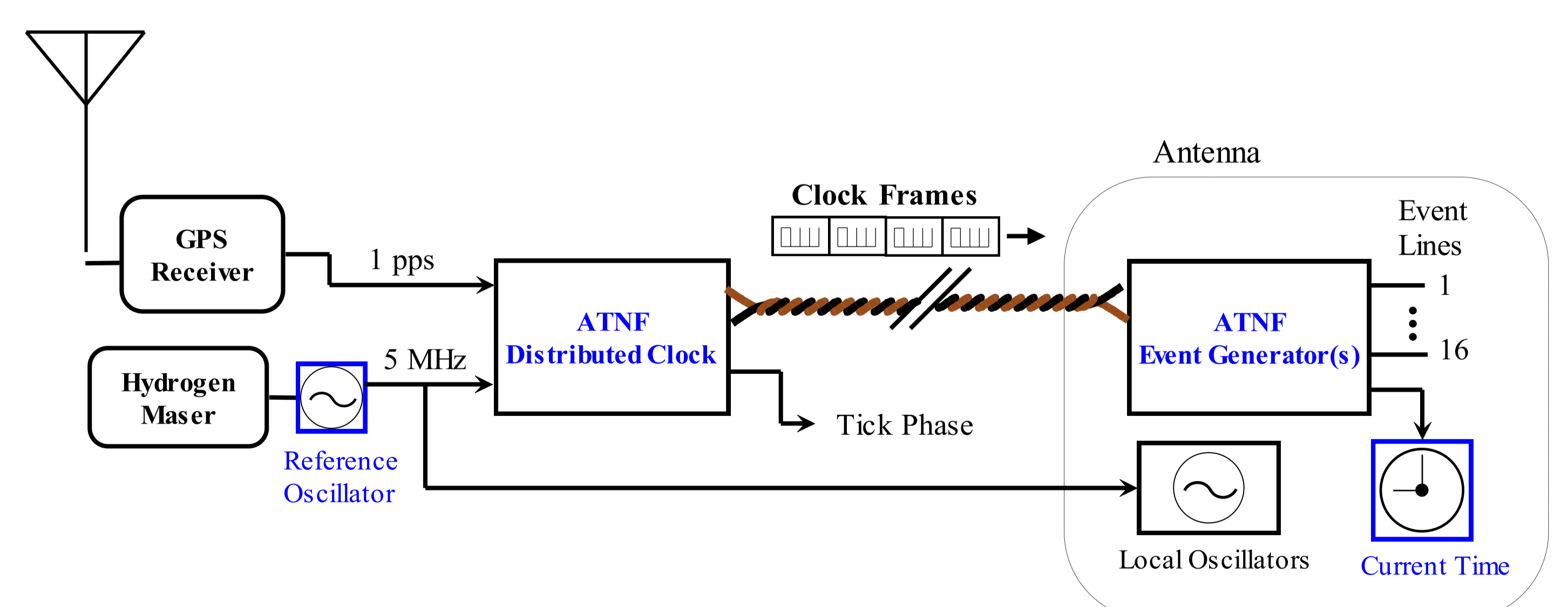

Figure 3: Basic architecture of the timing system

FOR FURTHER INFORMATION

Simon Hoyle
e Simon.Hoyle@csiro.au
w www.csiro.au/atnf