

MEASUREMENTS, ALARMS AND INTERLOCKS IN THE VACUUM CONTROL SYSTEM OF THE LHC



G. Pigny*, F. Antoniotti, J.P. Boivin, N. Chatzigeorgiou, J. Gama, P. Gomes, P. Krakowski, H. Pereira
CERN, Geneva, Switzerland



October 19, 2015
Paper ID: MOPGF112

Abstract

In the LHC beam pipes and cryostats, the pressure measurement covers a wide range, from 1500 mbar down to 10^{-11} mbar and even lower. If vacuum deteriorates, alarm signals are generated and sent to other systems, like cryogenics, accelerating cavities, kicker magnets. In addition, an unacceptable pressure rise in beam pipes generates interlocks to close the adjacent sector valves, thus isolating the sector, so that the pressure rise does not propagate. This pressure interlock is simultaneously forwarded to the beam interlock system.

This paper describes the instrumentation, the interlocks and alarms logic used in the vacuum control system of the LHC. We analyze the possible signal degradation caused by ionizing radiation or due to cable length, shielding and grounding. During the first LHC long shut down, several corrections were applied to mitigate radiation effects and improve signal integrity. The tests performed for the vacuum control commissioning and LHC machine checkout are also presented.

Vacuum Measurement

Membrane gauge

- 0 .. $2 \cdot 10^3$ mbar
- deformation induces piezo-resistive effect
- Resistance variation is a measure of the pressure

Penning gauge

- 10^{-5} .. 10^{-11} mbar
- Field emission of e- from cathode due to high E field (3kV)
- Increased ionization of gas molecules due to B field
- Ion current collected in cathode is a measure of the pressure
- Used for interlock purposes

Pirani gauge

- 10^3 .. 10^{-4} mbar
- Dependence of thermal conductivity on gas pressure
- Resistor under vacuum is heated to const. temperature
- Needed heating current is a measure of the pressure

Bayard-Alpert gauge

- 10^{-5} .. 10^{-12} mbar
- e- emitted by the heated filament
- E field inside the grid (150V) provokes oscillations
- Ions attracted to the collector
- Ion current is a measure of the pressure

Sputter Ion Pump

- 10^{-5} .. 10^{-9} mbar
- Composed of several Penning cells
- Field emission of e- from cathode due to high E field (6kV)
- Increased ionization of gas molecules due to B field
- Ion current collected in cathode is a measure of the pressure
- Pumping due to ions bombardment of the Ti cathodes
- Used for interlock purposes

Radiation Environment & Signal Integrity

Racks relocation

- High level of radiation caused by the collimation system at point 7
- Vacuum controls equipment in UJ76 has been moved into the TZ76 gallery (during LS1)
- This concerned 27 racks; the associated 280 cables were extended by up to 180 m
- In this gallery, the HEH fluence rate will be much lower and the SEEs negligible

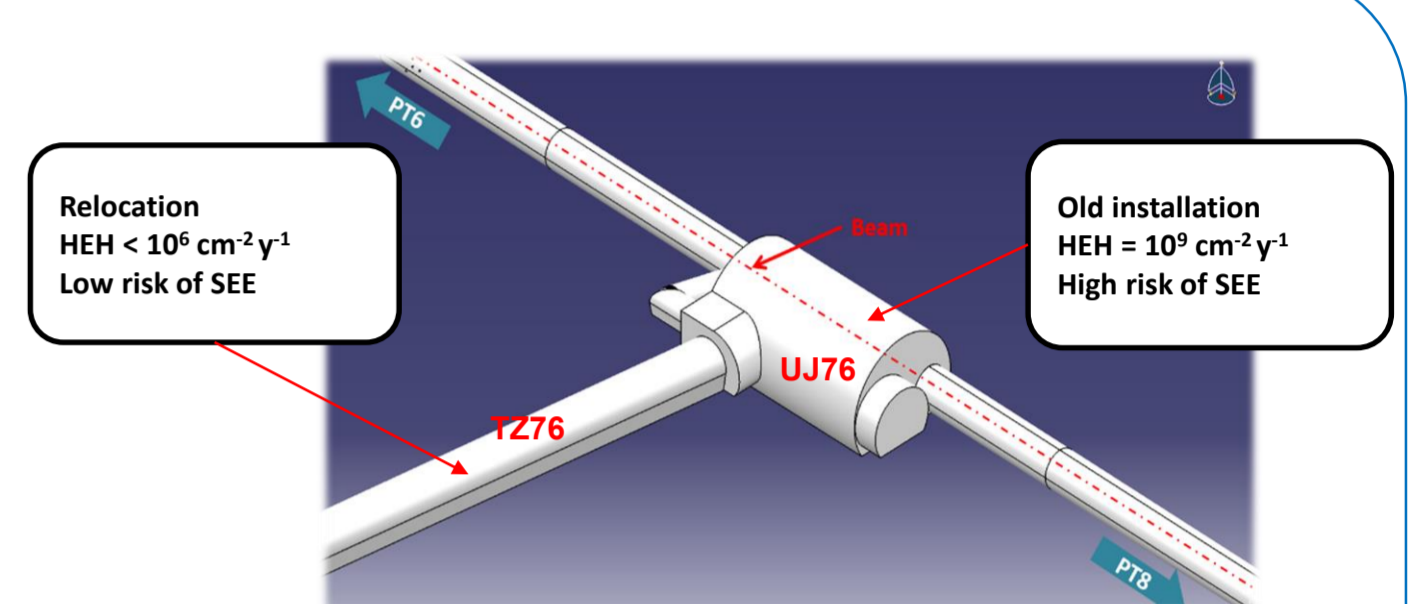

Irradiation tests

- New irradiation test carried out at Fraunhofer Institute
- Gamma radiation source of ^{60}Co
- 20 days irradiation; TID = 500 Gy
- Commercial Penning and CERN-designed Pirani electronics irradiated (3 samples)
- One sample of each placed outside the radioactive field as a reference
- Vacuum simulated by resistors
- Strong effect on Penning electronics from 15 Gy
- CERN-designed Pirani electronics stood up 500 Gy

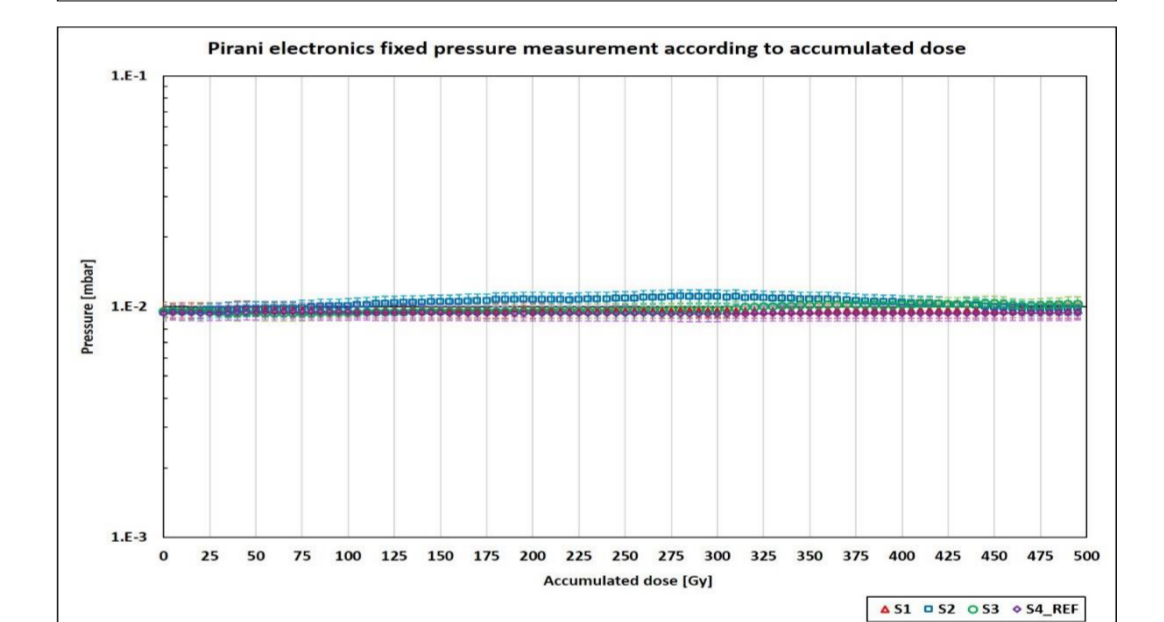
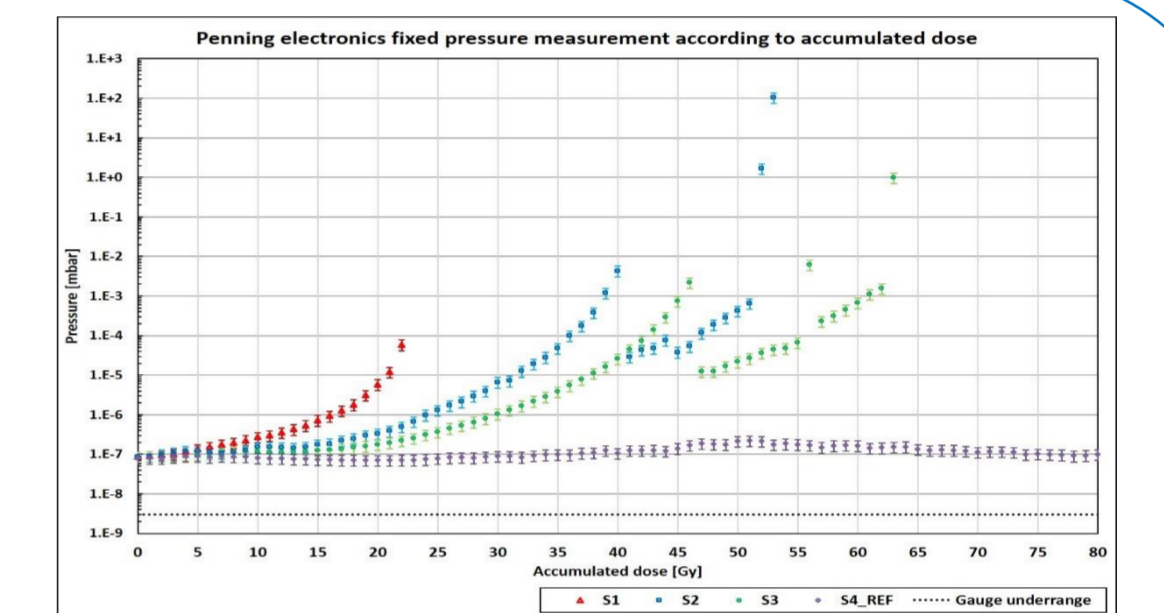

Signal integrity

- Too high resistance on the power return path
- Current consumption of the Penning electronics brought up a voltage across the wire resistance
- Common-mode voltage also present at the input of the AI module of the PLC (out of range)
- Parallel wires added to reduce return path resistance and common-mode voltage

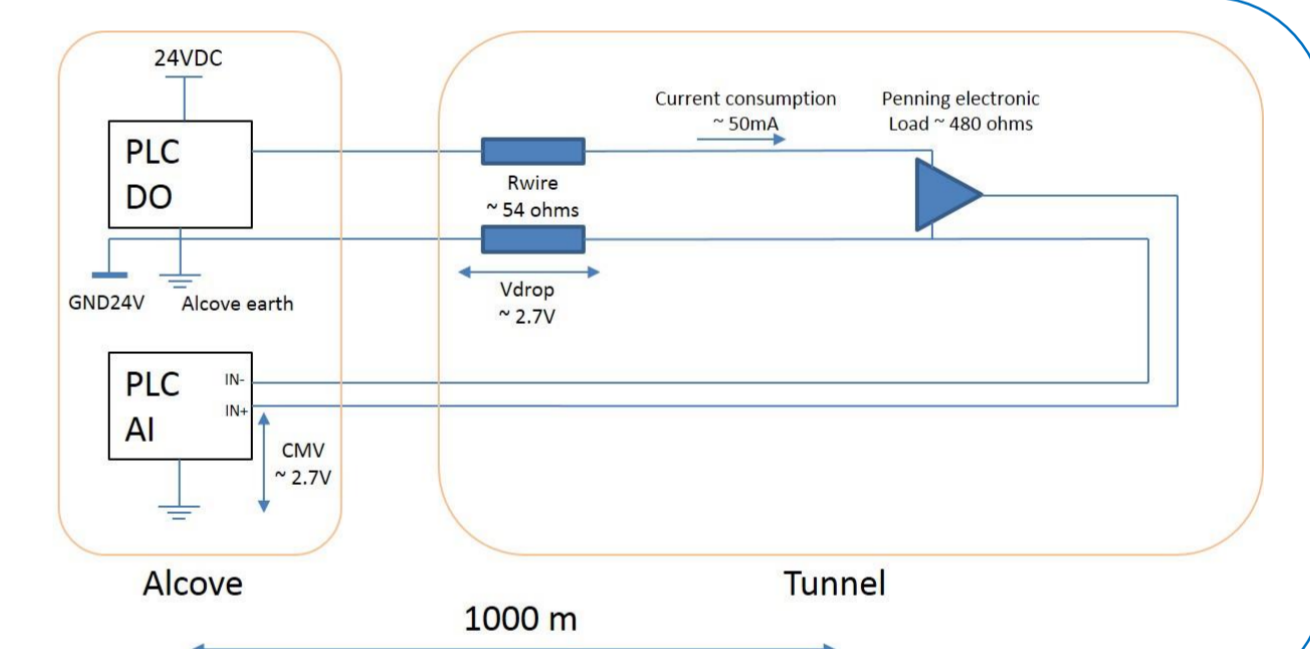

Vacuum Alarms & Interlocks

Alarms are binary signals sent to the operators' console, e-mail or SMS, to draw their attention to particular equipment status or situations. There are also alarms directly cabled to other systems, for information or to be used in their control logic.

- Operation
- Cryogenic system
- Kickers systems (MKI, MKB)
- RF & ADT systems

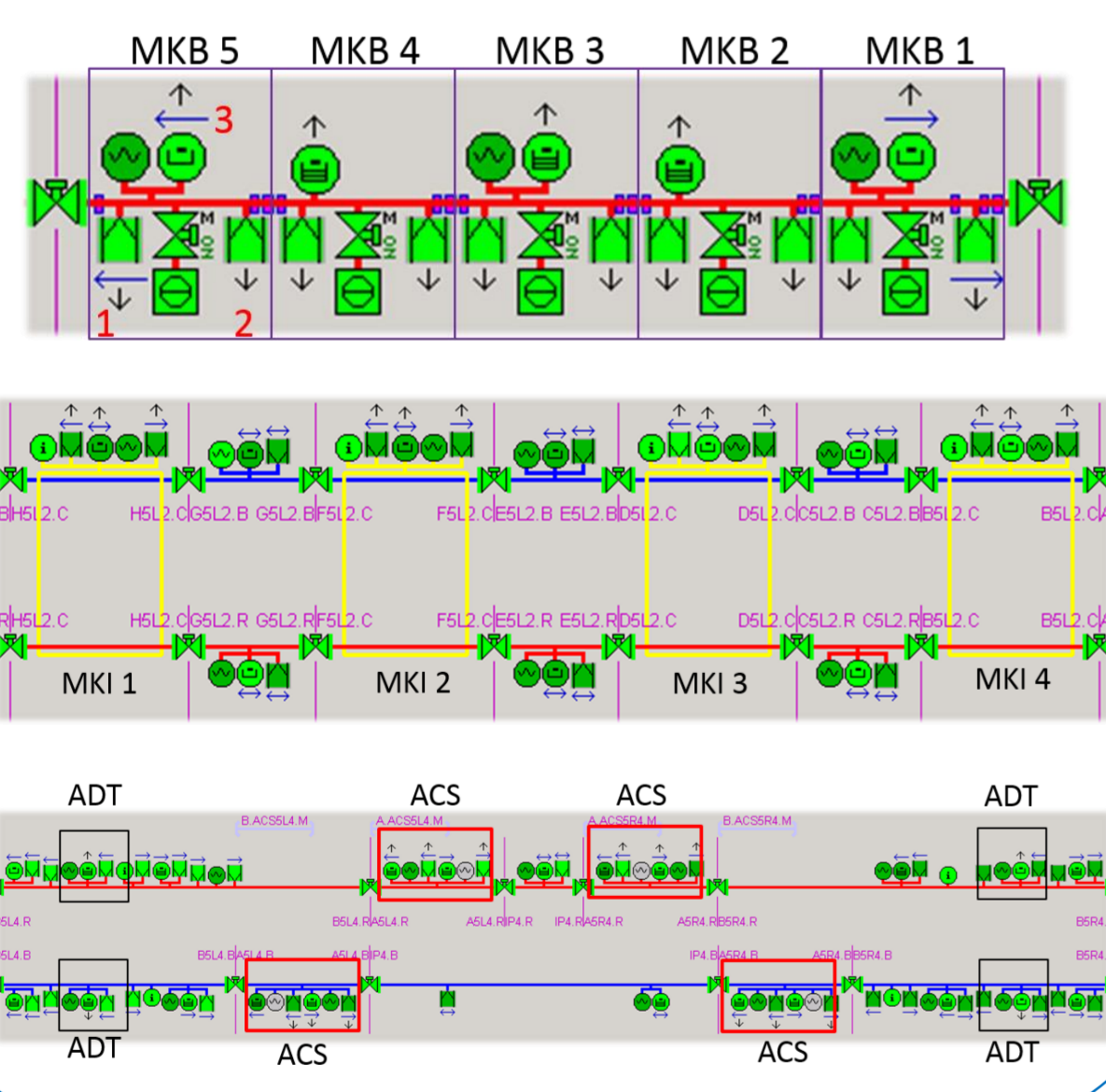

Interlocks are binary signals used within the vacuum system to prevent entering undesired states. They have a higher priority than the normal process logic or the operator's commands. Apart from the beam permit interlock, the vacuum control system does not interlock any other external systems directly.

- Sector Gate Valves (VVS)
- Beam Interlock System (BIS)

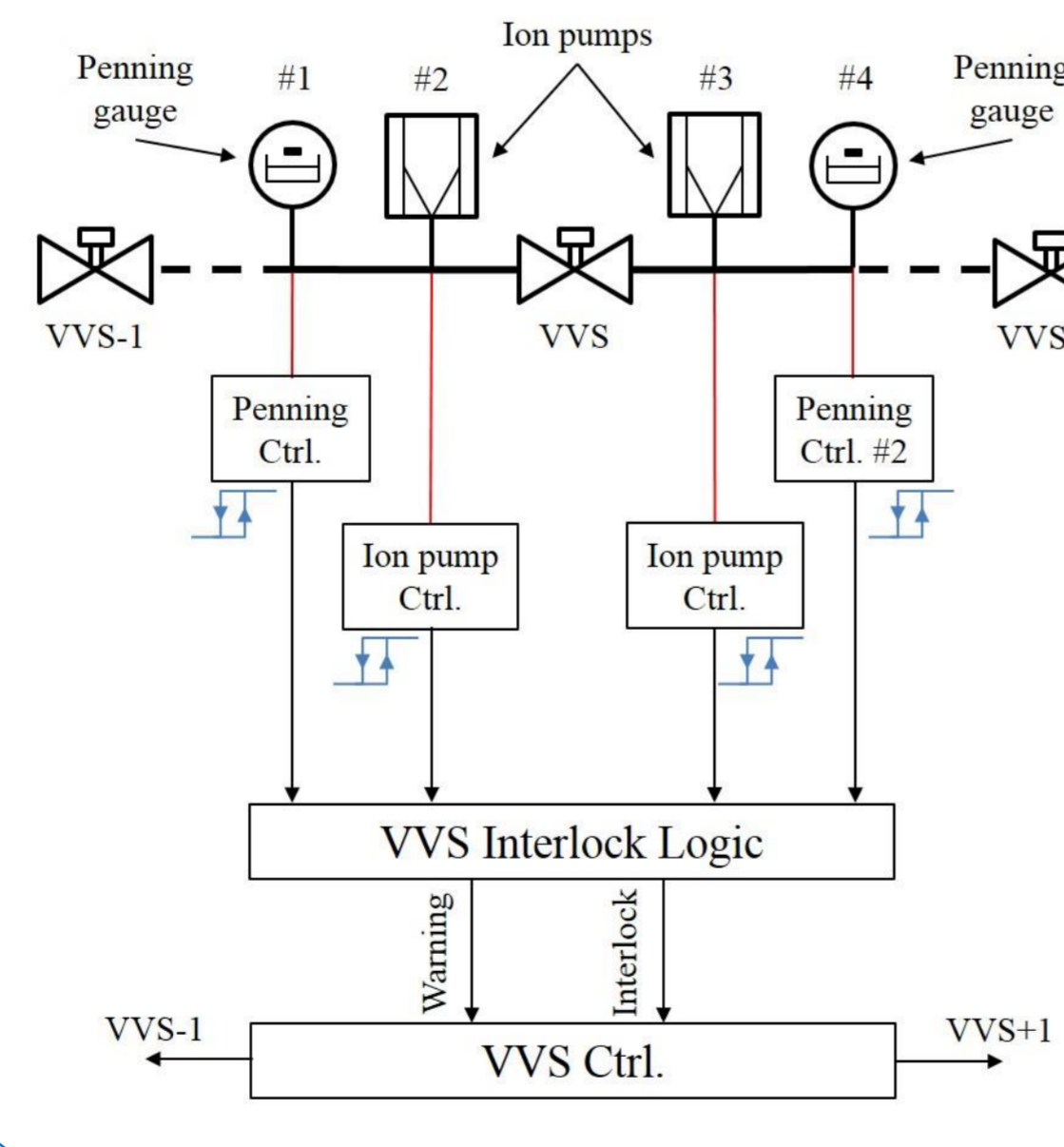

LHC commissioning & machine checkout

Commissioning

- 6 teams of 2 people for 4 months
- Test of all vacuum measurements chains, interlocks & alarms
- Amount of equipment involved in vacuum interlocks & alarms: 300 sector valves, 230 pairs of gauges, 590 Penning gauges, 350 ion pumps



Machine checkout

- Systematic verification of interlocks & alarms performed during the LHC machine checkout phase
- Check all the interlock sources for the vacuum valves; confirm that their status are sent correctly to the BIS
- Automated test sequence written in the vacuum SCADA
- Results stored in xml files

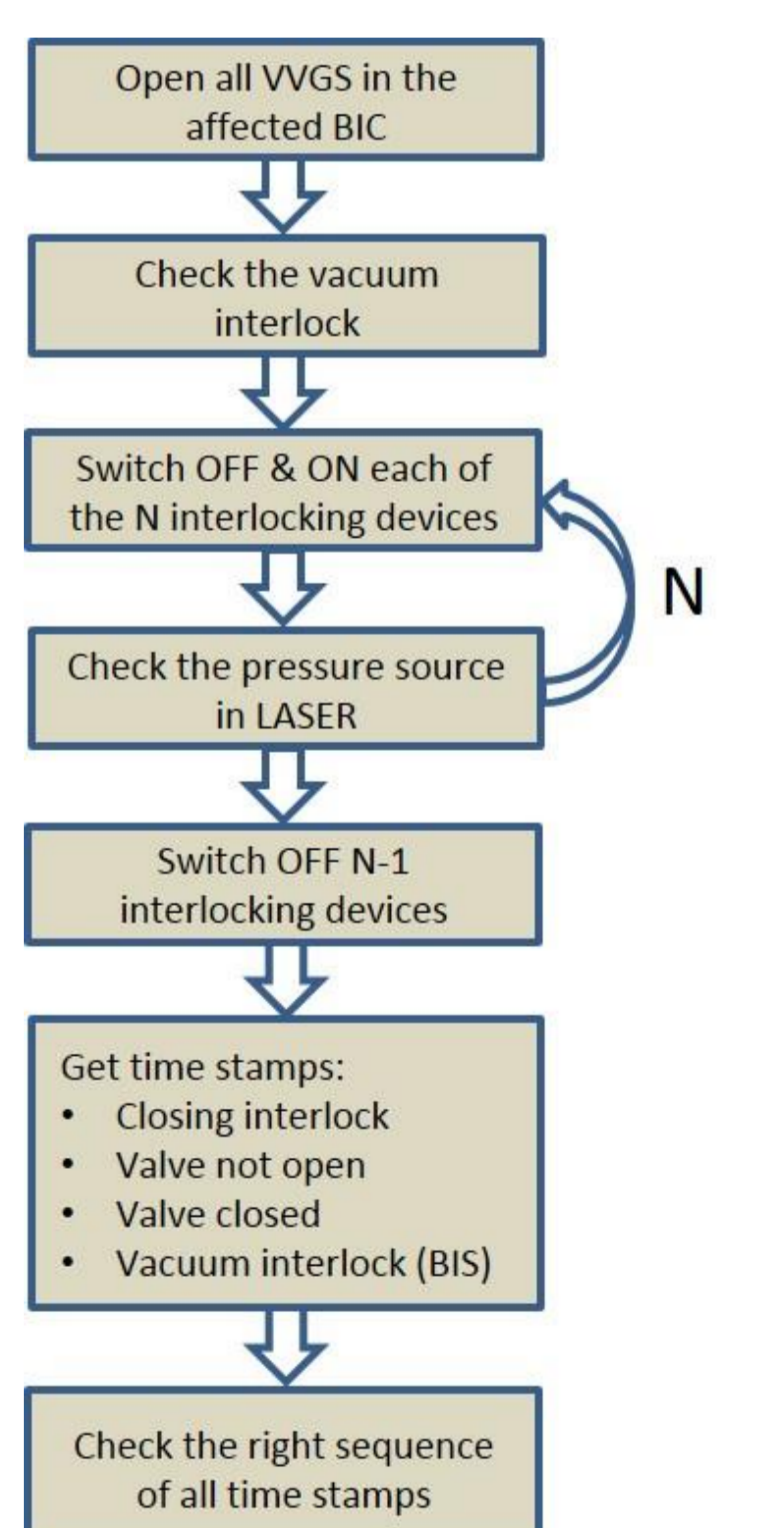

Conclusion

The vacuum measurement chains, alarms and interlocks must be reliable and are crucial to insure a safe operation of the LHC. The effects of ionizing radiation and the issues with signal integrity must be understood and minimized, to improve the system reliability. Attention must be paid to the calibration, settings and tests of every measurement chain.

During the LS1, important actions have been performed in this direction: racks relocation against radiation effects; grounding and cabling modifications for signal integrity improvements; systematic test of each interlock and alarm, from front-end hardware to the SCADA. Additionally, few cabling and Database errors were found and corrected. The vacuum interlocks are part of the LHC machine protection; during machine checkout, they were fully verified up to the BIS.

