

A DATA ACQUISITION SYSTEM FOR ABNORMAL RF WAVEFORM AT SACLA

M. Ishii[#], M. Kago, JASRI/SPring-8, Hyogo 679-5198, Japan

T. Fukui, H. Maesaka, T. Inagaki, T. Maruyama, T. Ohshima, Y. Otake, RIKEN/SPring-8, Hyogo 679-5148, Japan

T. Hasegawa, M. Yoshioka, SPring-8 Service Co., Ltd., Hyogo 679-5165, Japan

Abstract

At the X-ray Free Electron Laser (XFEL) facility, SACLA, we developed a data acquisition (DAQ) system to capture an abnormal radio frequency (RF) waveform for the diagnosis of suddenly occurring failures. The DAQ system consists of VME systems, a cache server, and a NoSQL database system, Apache Cassandra. When the VME system detects an abnormal RF waveform, it collects all the related waveforms of the same shot. The waveforms are stored in Cassandra through the cache server. Before the installation to SACLA, we ensured the performance with a prototype system. We installed the DAQ system into 34 LLRF VME systems at SACLA and six LLRF VME systems at a dedicated accelerator for the SACLA wide-band beam line. The DAQ system successfully acquired rare abnormal waveforms and contributed to the investigation of the failure analysis.

INTRODUCTION

At the X-ray Free Electron Laser (XFEL) facility, SACLA [1], driven with an 8 GeV linac, the stability of the phase and the amplitude of RF in each accelerating structure significantly affect the stability of the electron beam and the FEL intensity. It is quite helpful to collect the shot-by-shot RF data for a feedback control and the diagnosis of a failure source.

We have been using two types of data acquisition systems since the beginning of commissioning in 2011. One is a data logging system with a cycle of several seconds, which provides information for slow fluctuation, such as environmental temperatures and the flow of cooling water [2]. The other is an event-synchronized data acquisition (sync-DAQ) system that collects beam currents, beam positions, and the phase and the amplitude of the RF signals in synchronization with the beam operation cycle at the current maximum of 60 Hz [3]. Shot-by-shot data are tagged with a master trigger number to identify the beam shot to which the data belong. In addition, the sync-DAQ system collects RF waveform data every 10 min. If any fluctuations were observed in shot-by-shot data, it is important for the failure diagnosis to capture the waveform data of when the failure occurred. However, waveform collection every 10 min may not capture an abnormal RF waveform from a rare failure event that may occur only a few times a day.

[#] ishii@spring8.or.jp

In order to collect the abnormal RF waveform data for a failure diagnosis, we developed a data acquisition system to acquire abnormal RF waveforms (abnormal WFM-DAQ system) in 2014. The DAQ system is useful for analyzing the phenomenon, because it has more information than point data, which are sampled from a part of waveform data. In this paper, we describe the installation of the abnormal WFM-DAQ system and an example of the acquired data.

ABNORMAL WFM-DAQ SYSTEM

Low-level RF Control System

The low-level RF (LLRF) control system consists of the 74 RF units of the SACLA linac. Figure 1 shows an overview of an RF unit in the LLRF control system. A trigger delay unit (TDU) board, a DAC board, three ADC boards and a CPU board are installed in a VME crate. The TDU board generates the trigger signals to the ADC and DAC boards, a klystron modulator, etc., whose timing is determined by counting with the 238-MHz master clock. The DAC board generates the pulse modulation pattern signals to the IQ modulator for controlling the RF phase and the RF amplitude. The ADC boards measure the phase and the amplitude of the RF cavity pickup signal from klystron (KLY), pulse compressor cavity, and two accelerating structures, and the high voltage (V_k) and the pulse current (I_k) of the klystron. The TDU board, the DAC board, and the ADC boards synchronize with the 238-MHz master clock.

The ADC board has four input channels. Each channel has four memory banks that can store 512 waveforms data in synchronization with the trigger signal. The data size of

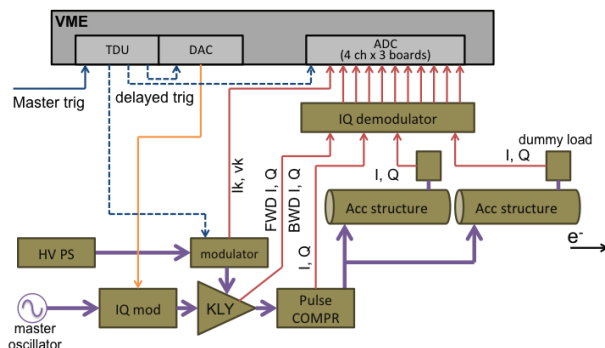

Figure 1: Overview of an RF unit in the LLRF control system.

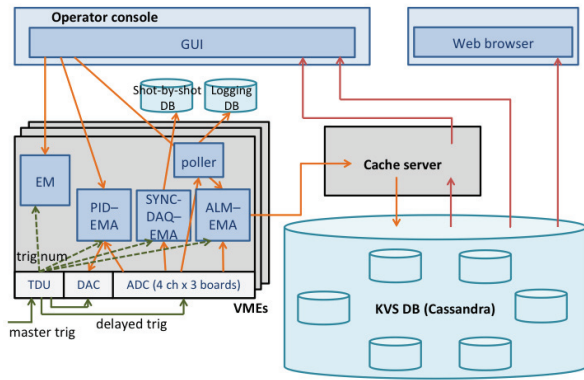

Figure 2: Diagram of abnormal waveform DAQ system.

DATA

Column name	Column value
1411013100200100:trig	12345678
1411013100200100:err	1
1411013100200100:wfm	Waveform data (binary)
....

Column name	Column value
1411013100401760:trig	12355678
1411013100401760:err	0
1411013100401760:wfm	Waveform data (binary)
....

Figure 3: Cassandra’s data structure.

a waveform is 4 KB for the 2048-point sampling or 16 KB for the 8192-point sampling.

Overview of the Abnormal WFM–DAQ System

The abnormal WFM–DAQ system consists of VME systems, a cache server, and Apache Cassandra, which is a key-value database system. Figure 2 shows a diagram of the abnormal WFM–DAQ system.

The ADC board generates an interrupt signal when it detects an abnormal waveform by comparing it with a reference waveform. When the difference between a sampled waveform and the reference waveform exceeds a defined allowance, the sampled waveform is categorized as an abnormal waveform. The width of the allowance can be changed from the application software [4, 5].

An abnormal WFM–DAQ process (ALM–EMA) receives the interrupt signal and acquires all the related waveforms. The waveform data are transferred to the cache server and stored in Cassandra. The stored data can be plotted in a graphical user interface (GUI) or a web browser.

Processes Running in the VME System

In the VME system, the following five processes are running:

- Equipment management process (EM) [2]
- Data logging process (poller) [2]
- Sync-DAQ process (SYNC-DAQ-EMA) in synchronization with the beam operation cycle [3]
- Feedback process (PID-EMA) for the stabilization of the phase and the amplitude of the RF cavity with 100-ms sampling intervals [6]
- ALM-EMA, which was newly developed for an abnormal WFM–DAQ system [7, 8].

From the results of the validation conducted using a prototype system, we found that it takes 1.1 ms to transfer 16 KB of waveform data from an ADC channel. To prevent blocking the VMEbus access from PID-EMA, we tuned ALM-EMA so that it takes each waveform data at a 500-ms interval. The CPU load of ALM-EMA is less than 1% on a multi-core CPU board. Therefore, ALM-EMA does not disturb other processes [9]. A multi-core VME

CPU board is required for the LLRF VME system with ALM-EMA.

Database System

The requirements for a database system are high writing performance, fault tolerance, and treatment of variable-length data. Cassandra is suitable as a database for the abnormal WFM–DAQ. It is easy to increase the total throughput by adding more nodes to the system. We set up the Cassandra cluster system with six nodes and a replication factor of three. One node has two disks to acquire higher access performance by dividing the system space and the data storage space. One is a 460-GB system disk containing an operating system, Cassandra, transaction log system, and Java Virtual Machine. The other is a 3.6-TB data disk.

We designed a data structure to efficiently handle variable-length data such as the time series, trigger number, and error flag that indicate whether the waveform is normal or abnormal. The data structure is shown in Figure 3. One row key provides the information of one day’s signal. The row-key name is formed from a signal name in addition to a date string, and the row contains collections of columns. One column consists of a name and a value. The name is formed from the timestamp in addition to a key word such as “trig,” “err,” or “wfm.” Cassandra distributes the data to each cluster node under the hash value of the row-key. This data structure makes it possible to distribute data evenly into the Cassandra nodes [10].

The Cassandra cluster system has the concept of eventual consistency. From our measurement, the time required for guaranteeing data consistency between multiple nodes is as much as 1 s in the cluster system [11]. To prevent this inconsistency, we developed a cache server. The cache server keeps data for 2 s from the current time to complement Cassandra’s eventual consistency. The cache server writes the waveforms received from ALM-EMAs to the in-memory and Cassandra in parallel. When an operational GUI requires a waveform with a signal name and a timestamp, the cache server takes the waveform from the in-memory or

a)

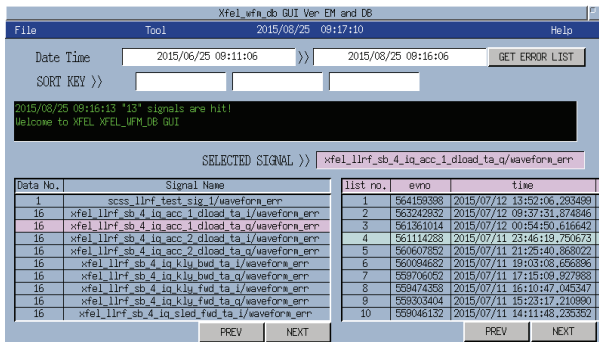

b)

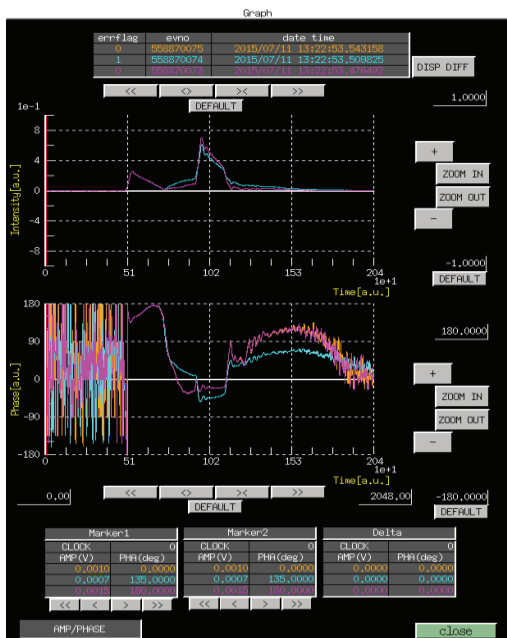

Figure 4: Management GUI for abnormal WFM-DAQ system. a) List panel of abnormal signal. b) GUI of an abnormal waveform viewer.

Cassandra in accordance with the timestamp and transfers the data to the GUI.

Graphical User Interface

We developed the GUIs for the WFM-DAQ system. Figure 4a) shows a list panel of abnormal signals. When a time period is set, the GUI acquires signals with an abnormal waveform for the set period from Cassandra and displays a list of these signals. When an abnormal signal is selected, the GUI displays the history of the abnormal signal. Upon the selecting of the event number that the operator wants to check, the GUI of an abnormal waveform viewer shown in Figure 4b) opens and plots the waveform. Further, a GUI was developed to set the parameters for ALM-EMA, such as the allowance value from the reference waveform and the repetition frequency. The GUI can issue a start/stop command. We also modified the integrated GUI for the LLRF control. The integrated GUI provides a one-click action of

create/destroy/start/stop to all ALM-EMAs and monitors the status of all ALM-EMAs.

Processing Flows

The processing flows of the abnormal WFM-DAQ system are as follows:

- An operator issues a start command for abnormal detection from the operational GUI to ALM-EMA. When ALM-EMA receives the command, the process sets a normal waveform as a reference waveform with a stable RF condition to the ADC board and transfers the reference waveform to Cassandra through a cache server. ALM-EMA waits for an interrupt signal of abnormal detection from an ADC board.
- By receiving the interrupt signal, ALM-EMA disables the abnormal detection of the ADC board and takes the meta information, such as the timestamp, master trigger number, bank number in which the waveform data are written, and the address point in the bank of the ADC boards.
- ALM-EMA makes all ADC channels switch the bank to preserve the sampled waveform data. The process captures not only the abnormal waveform but also the previous and the following waveforms of the abnormal waveform on memory.
- ALM-EMA sends each waveform with the meta information to Cassandra through a cache server and receives a reply message from the cache server.
- ALM-EMA enables the abnormal detection and waits for a start command from the operation GUI.

AN EXAMPLE OF ACQUISITION

We installed the DAQ system into 34 LLRF VME systems at SACLA and six LLRF VME systems at accelerator for the SACLA wide-band beam line (SACLA-BL1 accelerator) [12].

Usually, the DAQ system monitors the RF signal from the upstream accelerating structure as the target of abnormal waveform detection. When ALM-EMA detects an abnormal waveform, it acquires 36 waveforms (3 waveforms/ch * 12 ch) at minimum.

Figure 5 shows an example of the acquired abnormal waveform at the S-band accelerator of SACLA. Figure 5a) shows the trend graph of the phase value of the RF signal in the S-band accelerating structure. More than 25 degree discrepancy was observed at 13:22. Figure 5b) shows the normal and abnormal waveforms of the cavity amplitude of the RF pickup signal in the accelerating structure, and Figure 5c) shows the normal and abnormal waveforms of the cavity phase of the RF pickup signal. Figure 5d) shows the normal and abnormal waveforms of the klystron cathode voltage. The WFM-DAQ system captured all the waveforms belonging to the specific S-band RF unit and investigated the cause. In this case, we speculated that a high-voltage discharge in the klystron modulator caused the high-voltage deficit and the considerable change in the amplitude and the phase of the

SUMMARY

We developed a data acquisition system for abnormal RF waveforms. This system captures a suddenly occurring abnormal RF waveform and stores all the related waveform data in Cassandra. We have been successfully operating this system in 34 LLRF VME systems at SACLA and six LLRF VME systems at the SACLA-BL1 accelerator. We could determine the failure source in a specific RF unit. In the future, we intend to acquire waveform data from 74 LLRF VME systems. The collected data are helpful in improving the reliability of the accelerators.

REFERENCES

- [1] T. Ishikawa, et al., "A compact X-ray free-electron laser emitting in the sub-angstrom region", *Nat. Photonics* 6, 540-544 (2012)
- [2] R. Tanaka, et al., "Inauguration of the XFEL facility, SACLA, in Spring-8", *Proc. of ICALEPCS2011*, p.585-588, Grenoble, France, (2011)
- [3] M. Yamaga, et al., "Event-Synchronized data-acquisition system for SPring-8 XFEL", *Proc. of ICALEPCS2009*, p.69-71, Kobe, Japan, (2009)
- [4] T. Fukui, et al., "A development of high-speed A/D and D/A VME boards for a low level RF system of SCSS", *Proc. of ICALEPCS2005*, Geneva, Switzerland, (2005)
- [5] Y. Otake, et al., "SCSS RF control toward 5712 MHz phase accuracy of one degree", *Proc. of APAC2007*, p.634-636, Indore, India, (2007)
- [6] H. Maesaka, et al., "Recent progress of the RF and timing system of XFE/SPring-8", *Proc. of ICALEPCS2009*, p.85-89, Kobe, Japan, (2009)
- [7] T. Ohshima, et al., "Capture of abnormal RF waveform at SACLA", *Proc. of the 11th Annual Meeting of the Particle Accelerator Society of Japan*, Aomori, Japan, (2014)
- [8] M. Yoshioka, et al., "A data acquisition framework for the abnormal RF waveform at SACLA", *Proc. of the 11th Annual Meeting of the Particle Accelerator Society of Japan*, Aomori, Japan, (2014)
- [9] M. Ishii, et al., "A prototype data acquisition system of abnormal RF waveform at SACLA", *Proc. of PCAPAC2014*, Karlsruhe, Germany, (2014)
- [10] M. Kago, et al., "Development of a scalable and flexible data logging system using NoSQL databases", *ICALEPCS2013*, p.533-535, San Francisco, USA, (2013)
- [11] T. Maruyama, et al., "Development of web services framework for distributed database", *Proc. of the 11th Annual Meeting of the Particle Accelerator Society of Japan*, Aomori, Japan, (2014)
- [12] N. Hosoda, et al., "A control system for a dedicated accelerator for SALCA wide-band beam line", *ICALEPCS2015*, Melbourne, Australia, (2015)

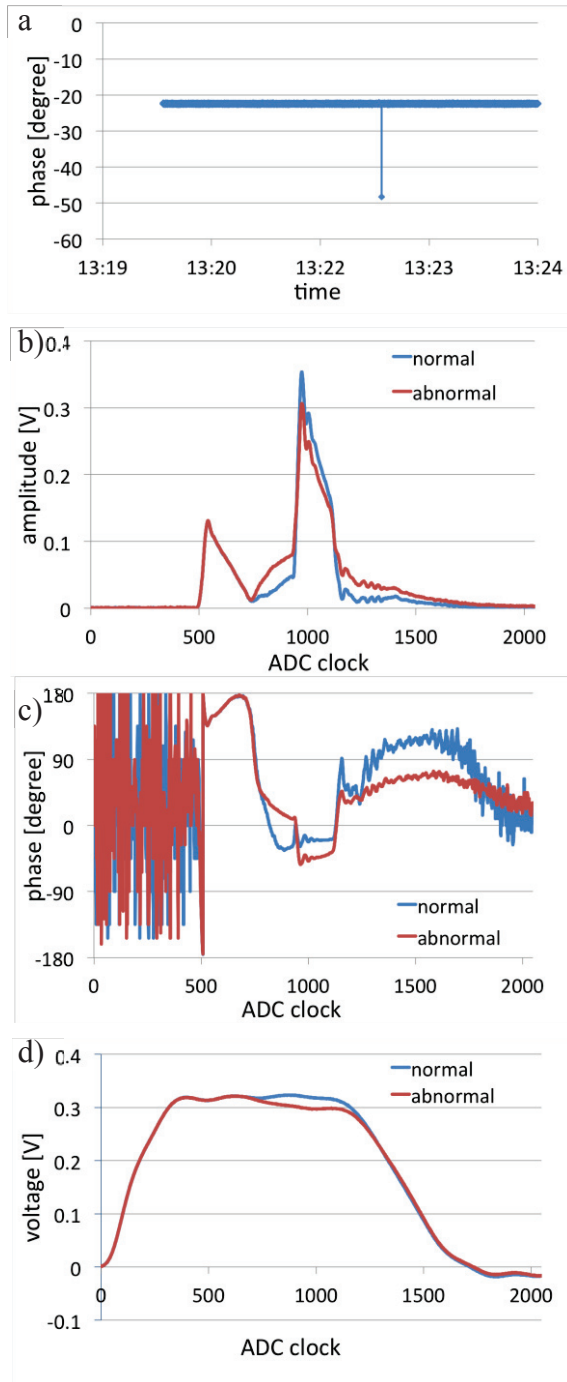

Figure 5: a) Trend graph of the cavity phase in the S-band accelerating structure. b) Normal and abnormal waveforms of the cavity amplitude of the RF pickup signal. c) Normal and abnormal waveforms of the cavity phase of the RF pickup signal. d) Normal and abnormal waveforms of the klystron cathode voltage.

RF power. Since this abnormal waveform frequently occurred in a specific RF unit, we replaced the modulator during the summer shutdown period. Currently, the failure has not occurred. As shown in this example, the WFM DAQ system can rapidly identify the cause of failure.