

## ERL TIME MANAGEMENT SYSTEM\*

P. Kankiya<sup>†</sup>, T. Miller, B. Sheehy, Brookhaven National Laboratory, Upton, NY 11973, USA

### Abstract

The Energy Recovery LINAC (ERL) at BNL is an R&D project. A timing system was developed in conjunction with other available timing systems in order to operate and synchronize instruments at the ERL. This paper describes the time management software which is responsible for automating the delay configuration based on beam power and instrument limitations, for maintaining beam operational parameters, and respond to machine protection system.

### INTRODUCTION

The Energy Recovery LINAC at BNL is an R&D project and has been constructed in a blockhouse at BNL's large complex [1]. It is advantageous to setup a prototype machine on the same site which has long running accelerators such as RHIC because of access to resources and expertise. The challenging part is to meet project specific needs that are unable to utilise the existing infrastructure. In case of ERL's timing system it was partly possible to use RHIC style delay generator boards but certain features required programming new or buying commercial off-the-shelf (COTS) delay generators. The timing clock and events are distributed to all parts of ERL such that Laser and RF are always phase locked. This is the basis for synchronizing all aspects of ERL behaviour. The timing system is clocked by a 4.69 MHz clock optically derived from the photocathode laser; the laser is itself phase-locked to the 704 MHz SRF gun that serves as the master clock of the system. The laser clock is distributed to the timing system, installed about 200 ft away from Laser room in a VME rack. The laser-clocked VME system triggers some hardware systems directly, and others are triggered by low jitter (10s of psec) COTS delay generators (Stanford Research Systems DG645), which are triggered by the VME system. The DG645's offer more flexibility in certain functions (eg, burst, inhibit, gate shape, pre-scaling) than the native VME system, and this hybrid approach expands the capability and adaptability of the timing system. This assembly of various delay units and monitoring software together constitute the timing system of ERL and is credited for tasks such as coherent operation of measuring instruments, automatic delay calculation, supporting system testing, integrating several key hardware components, beam parameter limitation, inhibiting diagnostic systems and Laser beam production.

### SYSTEM LAYOUT

The timing system currently comprises of two V202

\*Work supported by Brookhaven Science Associates, LLC under Contract No. DE-AC02-98CH10886 with the U.S. DOE.

<sup>†</sup> pkankiya@bnl.gov

delay modules installed in two different VME chassis and four DG645 boxes. A top level flow-diagram of timing signals is illustrated in Fig. 1. The inception of timing signals is at a V202 delay module. These modules are capable of decoding RHIC event link events [2]. A C++ class called Accelerator Device Object (ADO) [3] is created for controlling V202 boards. This ADO lets a user have control of each delay channel by providing fields for delay values, output pulse width, source of trigger etc. Using the ADO interface the board is configured to operate in external clock mode and is connected to 4.69 MHz clock generated by the photocathode laser. All output channels of 202 modules can be triggered externally, manually or at an event. The software representation of a DG645 is also realised by ADO. These units are all configured to be externally triggered and concurrently triggered by V202 channels with a maximum lag of 213ns lag (one clock cycle).

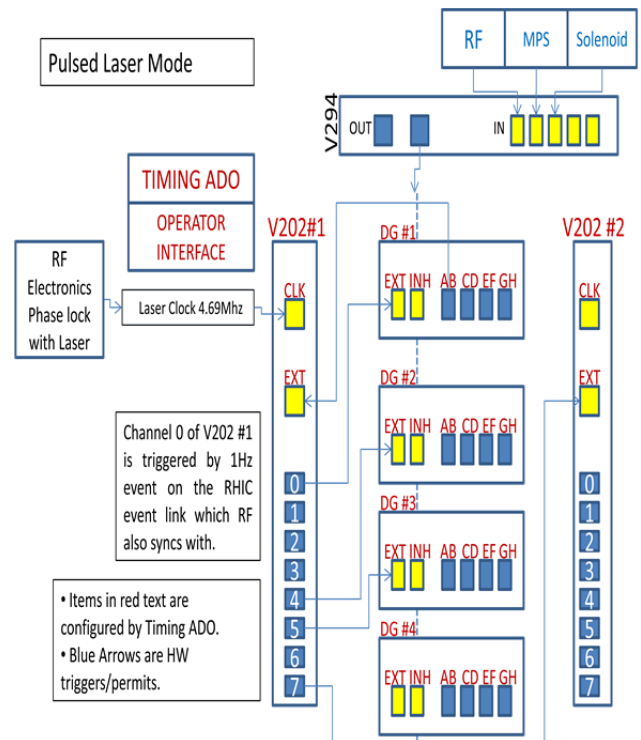

Figure 1: Block Diagram of the timing system with software and hardware components.

All configurable controls and statuses on these devices are displayed on user screens as ADO parameters. An ADO class referred to as master timing ADO is constructed to orchestrate timing signals across all ERL equipment via both styles of delay boxes such that the operator interface stays streamlined and unaffected by variety of hardware at lower level.

### Bunch Structure

As per design ERL is capable of operating in continuous wave (CW) and pulsed mode. CW means that both laser and gun run at the full laser rep rate of  $f_L=9.38$  MHz. In pulsed mode, the delivery of laser pulses to the gun photocathode and triggers to other diagnostics is structured. The laser operates at 9.38 MHz, and this is the maximum frequency at which electron bunches may be produced; a fast optoelectronic switch is used, with a variable width gate, to select a number of bunches into a macrobunch or “car”. The number of pulses may be arbitrarily large, and these macrobunches may be produced at rates of up to 10 kHz. Multiple macrobunches combine to form a “train”. This relationship is illustrated in Fig. 2.

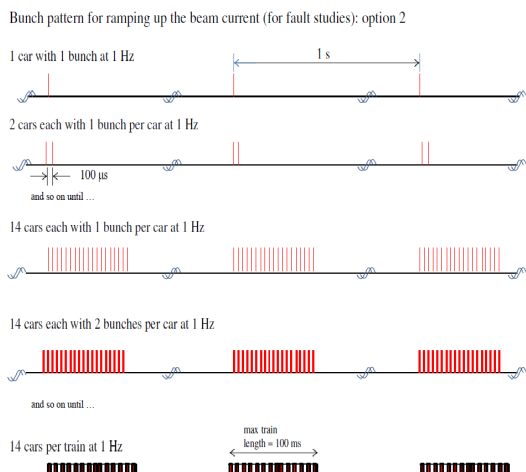

Figure 2: ERL bunch structure at different duty cycles with fixed macrobunch of 9.38 Mhz.

### Generation of Macrobunches

In case of pulsed beam mode keeping the afore mentioned structure in mind a combination of in house developed delay generator boards(V202) and COTS Stanford Research System’s DG645 are employed. V202 board as shown in Fig. 1 is responsible for generating the start trigger of the system. This is referred to as the start event and is repeated at 1Hz frequency. Thereafter the first of the four DG645s is triggered by this event, leading to the production of a burst of pulses. The burst parameters, such as frequency, delay, and period, are configured by the Timing ADO. Each burst produced by the DG645 device is a macrobunch train of the ERL beam.

### Clock and Synchronisation with RF

The frequency of the SRF gun is chosen to be 703.75 MHz, or the 75th harmonic of the 9.383 MHz bunch spacing frequency of RHIC [3]. A PLL matched at the 75th harmonic of the laser pulse train and feeding back to the laser oscillator cavity length phase-locks the laser to the 703.75 MHz master clock. Synchronicity between RF pulsing in the cavities and the timing system is achieved

by initiating both from the same event on the RHIC event link.

### Jitter and Insertion Delays

Due to the presence of multiple types of delay generators and that the timing system hardware is split up between two chassis there are multiple contributors to the jitter of the overall system. The jitter values of a V202 externally trigger channel is on the order of 400ps. DG645 has a low jitter value of about 12ps and an insertion delay of 80ns. The timing ADO compensates for insertion delay introduced in the sequence by calculating the total insertion delay and adding that to the delay value configured for the fastest device; the Laser.

### Start of Laser Train

The downstream DG645s are used to trigger various instruments and laser itself. Each unit has 4 output gates, AB, CD, EF, and GH, determined by the eight edges A-H. Each edge is software-configured relative to any other edge or T0. Output AB of DG645 #2 is chosen as the trigger for the electro-optical switch inside of the laser. Since the macrobunch might contain only one pulse, we want all measuring devices to be triggered in time to measure the first pulse. For each device “dev”, the trigger comes before the optical switch opens, and the optical switch opens at  $T0 + \delta_{max}$ , where  $\delta_{max} = \max(\delta_{cam}, \delta_{ICTLi}, \delta_{bFC}, \dots)$ , so:

$$XXdev = T0 + \delta_{max} - \delta_{dev}$$

XXdev is the delay value to set on corresponding delay generator channels. This equation ensures the laser gate channel is one with longest delay value.

### Maintaining Beam Power Limitation

Another key aspect of this ADO is to ensure the beam operation bounds are not violated. This is a preventive step to assure that the system never reaches the radiation safety limits of the designed accelerator. Any changes in the operating beam current, QE of the cathode [4] or maximum beam power are entered via the user interface described in a following section. The duty factor of the ERL operation cycle is limited by this equation:

$$f * w \leq I0 / (Plmax * QE)$$

### Automation Tasks Performed in Timing ADO

To simplify the task of an operator and reduce human error, the ADO automates the calculation of the length of the train and makes use of this value to set the gate width of selected beam diagnostics that need to remain open for entire time of beam cycle. The calculation of delay value is based on the special needs of electronics such as trigger width, and position. These settings are entirely automated and require no human intervention once the burst count is set.

### OPERATIONS

The ERL includes beam diagnostics required to characterize and tune beam parameters, as well as for machine protection [4]. Experimental data acquisition systems require a precision timing reference and triggers to properly coordinate their measurements in coincidence with the beam. It is of critical importance that these devices are triggered at a precise time with respect to the beam pulse for correct measurement of beam properties and losses. After deliberate discussions and testing with expert instrumentation engineers the pre-trigger values for these electronics have been determined.

The timing of most of the trigger signals have been measured using a Lecroy WR610Zi Oscilloscope with

mixed signal input module (MSO), as shown in Fig. 3. The MSO provides 18 digital channels for various trigger and gate signals to be plotted on the scope display. The operators and engineers find this setup invaluable to the timing system of an R&D accelerator. Measurement signals are digitised by feeding them to high and slow speed digitiser VME boards namely 3123 and 3122 which themselves are triggered by the timing system to start measurements. The Analog signals on the scope in Fig. 3 show live beam charge measured by the faraday cup.

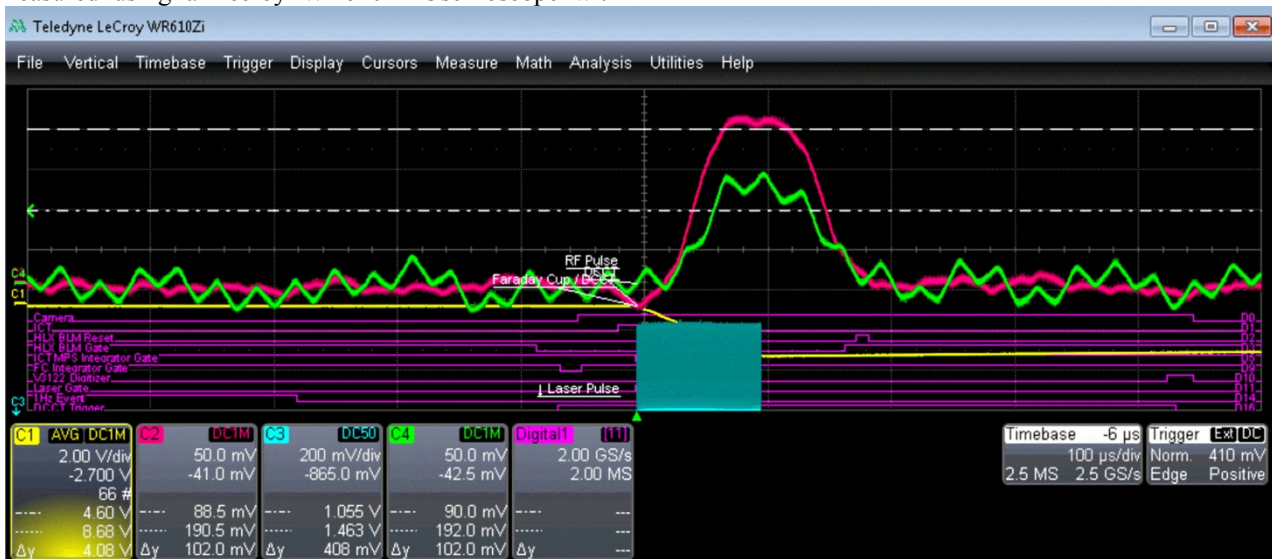

Figure 3: ERL accelerator instrumentation with the laser gate on a digital multiplexed oscilloscope.

### USER INTERFACE

The User Interface of timing control system has been split into three categories. Each screen utilises the parameter editing tool (PET) tool for displaying critical operational parameters. PET is a customary user interface application developed at CA-D for controlling and measuring data represented as ADOs. First screen is a consolidation of all clients of timing system denoted by a channel on a delay generator and there delay configurations. After the initial testing phase, most of the values on this screen are governed by the master ADO interface rather than the operators. The second screen displayed in Fig. 4, is used to control beam parameters such as power of operation, QE at the start of a day's run, and beam current. Train parameters can be changed at the discretion of the shift leader from this screen. Another screen keeps track of default configuration of the DG645 boxes and lets an engineer control them via the master Timing ADO.

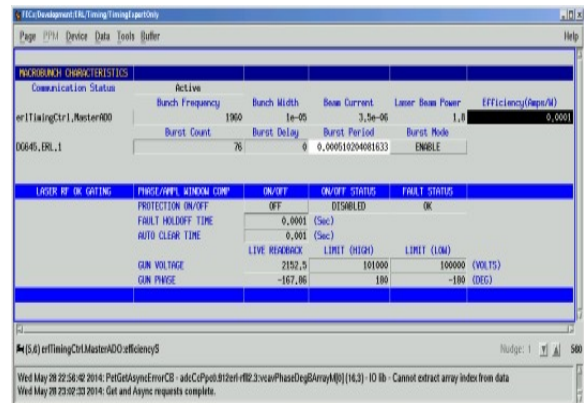

Figure 4: Timing expert only user interface screen.

### TERMINATION OF TRAIN

It is possible to terminate the timing signal generation under three conditions:

1. At-will, from the operating console
2. When a finite programmed macrobunch sequence has completed

### 3. When RF system has any faults.

In case (1), the burst from DG645 #1 has to be terminated. This can be accomplished by sending the command 'BURM 0' to the delay generator. This disables burst mode. According to SRS engineers, this will terminate the burst within approximately 50 msec. To start a new acquisition, 'BURM 1' must be sent to re-enable burst mode, so this command should be part of the command sequence preceding each acquisition. In case (2), acquisitions will terminate naturally, as the burst sequence ends, and no further triggers are received by the laser optical switch or the instrumentation. At present there is no provision to communicate the end of the acquisition back to the control system. If this becomes necessary or desirable, it can be achieved by polling the status byte of DG645 #1. In case (3), laser emission will be terminated promptly through the machine protection system (MPS), which gates the signal to the optical switch. Electron beam will also cease, so it is not critical that data acquisition stop immediately. To avoid needlessly filling digitiser buffers, it would be desirable to stop acquisitions more quickly. This is accomplished by logically ANDing three signals: (a) a duplicate MPS signal inverted, and applied to the INHIBIT inputs of both DG645 2, 3 and 4 (applying to #1 will not work, as the INHIBIT inhibits new triggers, and will not terminate a burst that is in progress); (b) a health signal from RF system indicating TTL low, the good state (c) the High Temperature Super Conducting Solenoid's quench status.

### COTS DG645

COTS devices were an attractive option for ERL timing controls in order to reduce costs by leveraging off of industrial solutions that could meet system requirements. An ADO class controls the assembly of DG645s at ERL communicating via TCP/IP. There are several key features that led to these devices being selected. The burst mode feature that allows the production of a high frequency train of triggers was a system requirement supported by the DG645. These units were bought with intent to make use of pre-scale trigger option which permits skipping external/internal trigger and prevents a channel from producing an output. This aspect was not utilised in the case of the ERL because the device does not keep track of the start of the train, and a random trigger input that will be skipped instead of a synchronised multiple of programmed pre-scale multiplier. One of the limitations of the device was observed when an output channel was set to large pulse width; this led to generating the rate error light indicating that several triggers were missed. This default grouping of all output channels confines the system to have a maximum delay value to keep operating at high beam frequency. Another drawback of this device is absence of ability to disable an output channel individually. In absence of beam it is desirable to turn off certain instruments whereas some of them must be triggered to avoid saturation of electronics. To overcome this

inadequacy, all diagnostics were regrouped so that instruments that have similar trigger needs are connected to same DG645 box.

### CONCLUSION

A timing system prototype has been designed and well tested with live beam of 2 KHz rep rate at BNL's Energy Recovery LINAC. A hybrid system composed of a variety of delay generating units with adjustable delays has been implemented. Key milestones for the ERL project have been met, and operations are in the Gun to Dump phase [5]. For future projects, COTS hardware such as MRF timing systems can be considered as an alternative to individual Delay Generator units in case of standalone accelerator projects. Efforts to make the user interface more operator-friendly to non-experts will continue.

### REFERENCES

- [1] L.T. Hoff, J.F. Skelly, "Accelerator devices as persistent software objects", Proc. ICALEPCS 93, Berlin, Germany, 1993.
- [2] B. Oerter, C.R. Conkling, "Accelerator Timing at Brookhaven National Laboratory", Proc. 1995 Particle Accel. Conf., 1995.
- [3] I. Ben-Zvi, et al., "The Status of the BNL R&D ERL," ICFA Beam Dynamics Newsletter, No. 58, August 2012, p. 151.
- [4] Wencan Xu, et al, "SRF Guns at BNL: first beam and other commissioning results.", MOIOB03, Proceedings of SRF2013, Paris, France.
- [5] Toby Miller, et al, "Current Measurement and associated machine protection in the ERL at BNL", WEIALH2048, Proceedings of ERL 2015, Stony Brook, USA.