

SODIUM LASER GUIDE STAR EMULATION

I. Price, RSAA, Australian National University, Australia
 R. Conan, GMTO Corporation, Pasadena, CA 91101, USA

Abstract

In the era of extremely large telescopes (ELT) an adaptive optics (AO) system with artificial guide stars is an essential part of the optics between the source and the scientific instrument. In the case of the Giant Magellan Telescope these guide stars are formed by stimulating emission from Sodium atoms in the upper atmosphere with lasers launched from the side of the telescope. Moreover, they are resolved by the adaptive optics system so Shack-Hartmann wavefront sensors record elongated spots. Cost effective proof-of-concept systems for investigating control algorithms must be built for deployment in optics labs or on small telescopes. We present a hardware and software system that mimics the propagation of a single laser guide star (LGS) through the Earth's atmosphere and the optics of the Giant Magellan Telescope, using source motion and brightness modulation to simulate the source extension. A service oriented architecture allows adaptive optics scientists to construct images from different LGS asterisms and build non-real-time closed-loop control systems in high-level languages.

SODIUM LASER GUIDE STARS

A Sodium Laser Guide Star (LGS) is an artificial source created from Sodium atoms in the upper atmosphere and used for wavefront sensing as part of Adaptive Optics systems. Laser light at the 589 nm Sodium D2 line wavelength is propagated upward from a small telescope located alongside the main telescope. The photons from the laser interact with a naturally occurring population of Sodium atoms at an altitude of around 90-100km, exciting a shell electron. When the electron returns to its original energy level it emits a photon. Although the Sodium atoms are stimulated by a laser the process is dominated by spontaneous emission events. Ideally all of the energy from the outgoing laser beam would be delivered to atoms at a single altitude. In practice photons are absorbed all along the path through the Sodium layer, based on the remaining laser energy and the Sodium density. This results in a column of point sources that radiate some light back towards the main telescope, forming a laser guide star. Adaptive Optics systems use a wavelength filter to optically separate light from the laser guide star from the sources of scientific interest and natural guide star(s), and feed it to a laser guide star wavefront sensor (LGS WFS).

Shack-Hartmann wavefront sensors are based on lenslet arrays and imaging detectors such as CCDs. In essence, the pupil of the main telescope is divided into small patches, typically 100 to 200mm across. Each lenslet transforms the tip and tilt of the wavefront over the patch into a spot on the detector. Deviations in the spot positions gives an absolute measurement of the local tip and tilt of the wavefront. All lenslets in the WFS are observing the same LGS, but they

each have a slightly different point of view, as illustrated in Figure 1. In the era of extremely large telescopes the size of the primary mirror is significant compared to a 15km long source 90km away. For a 25m diameter telescope, the spot elongation for the lenslet the furthest from the laser launch location will be 9.5". In contrast, a natural guide star spot has a typical size of 1".

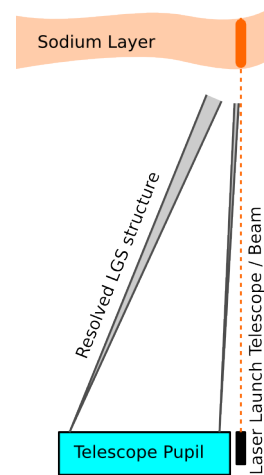

Figure 1: Column structure of the laser guide star source in the atmosphere and the variation of the angular size of the source with position in the telescope pupil.

Lenslets that sample the pupil far from the location of the laser launch telescope resolve the vertical structure of the LGS producing an elongated spot on the WFS detector, as shown in Figure 2. This distributes the signal from the LGS over more pixels than would be the case for an unresolved spot, increasing the error in spot position measurements and limiting the range of tip and tilt that can be measured without clipping of the input. Clearly the elongation of the spots has implications for the algorithms applied to WFS data for wavefront correction.

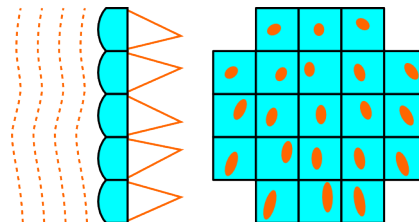

Figure 2: A distorted wavefront incident on the lenslet array of a Shack-Hartmann wavefront sensor (left) and the elongated spots in the image plane resulting from a laser launch telescope effectively located near the top edge of the pupil (right).

EMULATING ELONGATION

In order to emulate laser guide stars in a lab, an optical system must be designed that scales the telescope-atmosphere system down to fit on an optical table and match the physical pixel size of available detectors. The telescope in this case is the Giant Magellan Telescope (GMT). The details of the optical design are not presented here, but suffice it to say a 10km LGS column maps to a small fraction of a millimeter in the lab. While no lab light source has the intrinsic physical structure required, an effective source can be generated by moving a point source during an exposure. For the range of travel and precision required a laser LED fed fibre is mounted on a precision piezo XYZ-stage. The position is set by an analogue input voltage for each of the stage axes. As well as moving the stage, the intensity profile of the source can also be controlled by modulation of the laser diode drive current. Many COTS laser LED controllers support current modulation via analogue input voltage signals. This scheme was used as it consolidated the LGS control scheme into four analogue voltages.

The point of adaptive optics is to correct wavefront errors introduced by atmospheric turbulence. The time variation in this turbulence is dominated by movement of layers of the atmosphere, driven by winds. In a lab experiment turbulence is usually introduced by movement of phase plates. These optical elements have specifically structured optical aberrations. In the GMT emulation system three separate phase plates are used, each mounted on a rotary stage. Suitable placement of the stage along the optical axis sets the equivalent altitude of the turbulent layer. The rate of rotation of the stage sets the windspeed.

An adaptive optics system for the GMT will need to have a control loop rate of at least 500Hz. With an emulated LGS the loop rate is limited to about 1Hz. In each cycle an exposure is taken for each LGS. During the exposure the position of the source and the source intensity are varied to emulate a LGS. When the exposure is complete the source is moved to the starting point of another LGS. At the end of each cycle the phase plates are rotated through the small angle corresponding to the wind speed and the control loop rate under test. This changes the wavefront at the WFS which affects the location of the spots on the image detector. The images recorded at each cycle are processed to compute the wavefront error and ultimately drive wavefront correction for closed loop control.

ARCHITECTURE

The LGS emulation system is one part of a general optomechanical control system. The primary user requirements driving the software design were to enable simple integration with AO algorithms written in high-level languages, have the flexibility to redeploy the components for other experiments, and to be able to operate the system remotely. This naturally leads to a layered service-oriented architecture with minimal coupling between components at the low layers. It was also highly desirable to implement the lower-level control soft-

ware for the Linux OS and utilize open source components. This guided selection of the hardware that interfaces with the lower layer control computer(s). An overview of the architecture is given in Figure 3.

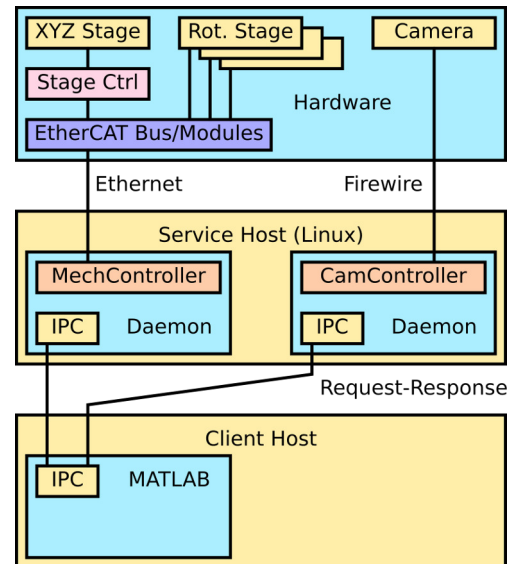

Figure 3: An overview of the hardware and software architecture of the control system.

System

From a control perspective, the rotary stages carrying phase plates are simply bipolar stepper motors and a home position indicator. Similarly, generation of an LGS profile amounts to generation of a four channel analogue output voltage signal. The EtherCAT fieldbus technology was chosen to implement all of these hardware controls, with all modules connected to a single bus coupler. This allows utilization of the open source Etherlabs IgH EtherCAT master and low level control from a Linux host. A digital output module was also included to allow the exposure of multiple cameras to be synchronized via the external trigger mechanism, and to implement laser safety interlocks.

The imaging devices at the core of the LGS WFS, and at other places in the optics, were selected based on pixel size, array size, readout noise, the maximum exposure time and cost. Although many camera interfaces are supported under Linux, cameras from Point-Gray Research with firewire interfaces were chosen. The open source dc1394 library was utilized to control and acquire data with these cameras.

Software

The software architecture follows object oriented design principles within the service and hardware interfacing layers. Each significant hardware component is encapsulated into a single service. All services utilize a common architectural framework. The service level is structured around a multi-channel request-response communication pattern. Each channel services requests sequentially and blocks while a request is being serviced, but the channels themselves are

independent and operate asynchronously. The framework requires each service be classified as a specific type of abstract controller, derived from the pure virtual Controller base class. Image devices are classified as CameraControllers and the LGS and phases plates are bundled together as a MechanismController. Communication channels accept request messages, parse them, and instantiate concrete classes derived from the Request class. The double-dispatch mechanism underpinning the *Visitor* design pattern [1] is used to deliver specific requests to specific controllers. The controller services the request and delivers a concrete instance derived from the Response class back to the communication channel. Responses are loosely coupled to the request type but strongly coupled to the nature of the data that needs to be delivered back to the client. The Request, Controller and Response class hierarchies and the communication channels provide the software infrastructure of each service. Each of the abstract controller classes declare a virtual interface that has a one-to-one mapping to a subset of the concrete request types. The request types encapsulate a single logical operation applicable to the hardware involved. For example, the camera controller has methods that commence an exposure, retrieve the image data from a completed exposure and attempt to abort an active exposure. The mechanism controller class is more generic. It's interface supports homing and positioning stepper motors and analogue signals.

A concrete class derived from one of the daughter classes of Controller is implemented for each type of hardware interface. It is at this layer in the software that thread-safe access to hardware is implemented. For example, the firewire cameras are all supported by the Dc1394Controller class via the dc1394 API, with pthread primitives utilized to ensure asynchronous requests from different channel have well defined behaviour. A simplified class diagram for the core classes and concrete classes utilised for LGS emulation are given in Figure 4.

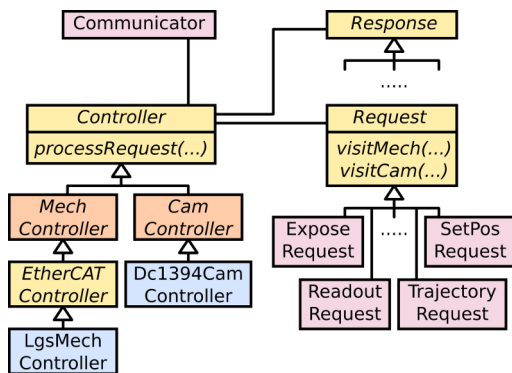

Figure 4: A compact class diagram for the laser guide star emulation services. Concrete classes from the framework are shaded in pink. The hardware specific classes that apply to a single service are shaded in blue.

Each service is implemented as a traditional unix daemon, instantiating a single concrete controller class and a single multi-channel communication class. The communication class provides the client-server support that facilitates remote

operation. A simple message protocol has been implemented on top of the 0MQ (ZeroMQ) API and its REQ-REP pattern. A unique port number is used for each communication channel.

Integration of one or more services into high level languages is based on a thin client C-API and the ZeroMQ library. Each function in the C-API constructs a request message, sends this to the appropriate service, and decodes the response. The interface for MATLAB is based on the MEX function mechanism and is built on the C-API. The MEX interface was utilized from the outset for alignment of the optical system, calibration and general instrument commissioning. An example WFS image verifying the instrument and control system has the capabilities required to emulate a laser guide star is shown in Figure 5.

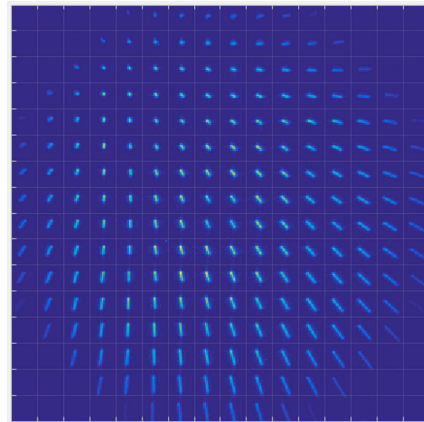

Figure 5: Data obtained from a WFS camera showing elongated spots as a result of moving the source and modulating its intensity during the exposure.

CONCLUSION

A modular service-oriented control system has been designed and developed to emulate the physical properties of laser guide stars. The hardware interfacing layer runs on the Linux operating system and leverages COTS hardware and open source software. A thin-client request-response communication model facilitates integration into high-level applications with a single third-party library, the only added dependency for the client. Initial results from a Shack-Hartmann wavefront sensor demonstrate that the extended physical structure of a laser guide in the upper atmosphere can be successfully emulated in the lab.

ACKNOWLEDGMENT

This work was funded by the Australian Federal Government's Education Investment Fund (EIF) and used equipment located in the Advanced Instrumentation Technology Centre at the Research School of Astronomy & Astrophysics, ANU.

REFERENCES

[1] E. Gamma, R. Helm, R. Johnson, J. Vlissides, *Design Patterns*, Addison-Wesley, ISBN 0-201-63361-2 (1994).