

## HEBT LINES FOR THE SPIRAL2 FACILITY. WHAT TO DO WITH ACCELERATED BEAMS?

L. Perrot<sup>#</sup>, J.L. Biarrotte, IPNO-IN2P3-CNRS, Orsay, France  
 P. Bertrand, G. Normand, GANIL, Caen, France  
 E. Schibler, IPNL-IN2P3-CNRS, Villeurbanne, France  
 D. Uriot, SACM/IRFU/DSM/CEA, Saclay, France

### Abstract

The SPIRAL2 facility at GANIL-Caen is now in its construction phase, with a project group including the participation of many French laboratories (CNRS, CEA) and international partners. The SPIRAL2 facility will be able to produce various accelerated beams at high intensities: 40 MeV Deuterons, 33 MeV Protons with intensity until 5mA and heavy ions with  $A/Q=3$  up to 14.5 MeV/u until 1mA current. We will present the final status of the high energy beam transport lines of the new facility. Various studies were performed on HEBT and beam-dump concerning beam dynamics, safety and thermo-mechanical aspects. New experimental areas using stable beams and the cave dedicated to radioactive ion production will be presented according to the scientific program.

### INTRODUCTION

The construction phase of SPIRAL2 is already launched within a consortium formed by CNRS, CEA and the region of Basse-Normandie in collaboration with French, European and international institutions [1, 2]. The facility will deliver high intensity rare isotope beams for fundamental research in nuclear physics, high intensity stable heavy ions beams, and high neutron flux for multidisciplinary applications. SPIRAL 2 will give access to a wide range of experiments on exotic nuclei, which have been impossible up to now. In particular it will provide intense beams of neutron-rich exotic nuclei ( $10^6$ – $10^{10}$  pps) created by the ISOL production method. The extracted ion beams will subsequently be accelerated to higher energies (up to 20 MeV/nucleon) by the existing CIME cyclotron, typically 6–7 MeV/nucleon for fission fragments. A low energy branch will be built to transport the beam to the DESIR hall. High intensity stable isotope beams and high power fast neutrons are other major goals of the facility. After two years of preliminary study, and following the decision to launch the construction phase, a complete design of the driver accelerator is presently under way [3]. This paper describes the studies performed on the high energy beam transport lines which deliver stable beams to experimental areas, radioactive production cave and beam dump.

### GENERAL LAYOUT OF THE DRIVER ACCELERATOR

The driver accelerator delivers CW beams of deuterons (40 MeV, 5 mA) and heavy ions ( $A/q=3$ , 14.5 MeV/A, 1 mA). The injector is composed of two ion sources (deuterons and heavy ions) and a common RFQ cavity (88 MHz) [4]. The superconducting LINAC is composed of two sections of quarter-wave resonators (QWR), beta 0.07 and 0.12 at the frequency of 88 MHz, with room temperature focusing devices [5, 6]. After the LINAC, ions are transported using various high energy beam transport (HEBT) lines according to experimental programs. Beams can be transported to the beam-dump, to experimental areas like the Neutrons For Science (NFS) area, the Super Separator Spectrometer (S3) or to the converter of the radioactive ions production area.

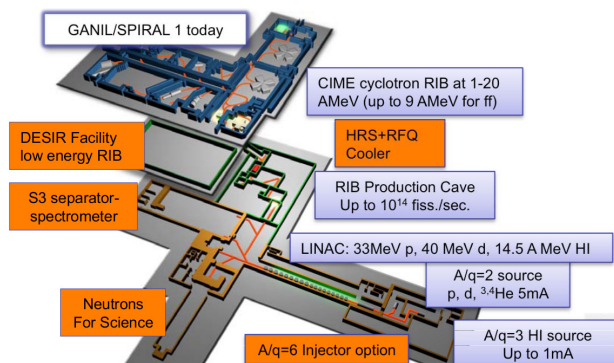

Figure 1: General scheme of the SPIRAL2 facility.

It must be noticed that in a second phase of SPIRAL2, a heavy ions source with  $A/q=6$  will be built with its associated injector. The LINAC will accelerate these ions up to 8.5 MeV/u. This point must be taken into account for the design of the HEBT lines.

### SPIRAL2 HEBT LINES

This paper will only focus on the beam transport description after the superconducting LINAC. In a first subsection we will give a compilation of the beam characteristics at the LINAC exit. In a second subsection, we will give the structure of the HEBT.

The well known TRACEWIN code is used for all beam dynamics calculations [7].

<sup>#</sup>perrot@ipno.in2p3.fr

### Beams Characteristics after the LINAC

From TRACEWIN, we extract transverse and longitudinal beams characteristics for all species after the LINAC. They are used as inputs for HEBT lines calculations. As an example, Table 1 gives a compilation of the beam emittances for Deuterons at minimum and maximum available energies.

Table 1: Beam specifications at the LINAC exit for Deuterons beam

Deut- erons	E=40 MeV	E=4 MeV
X-X'	$E_{norm}=0.1797\pi$ .mm.mrad $\alpha=-0.0729$ , $\beta=1.0691$ mm/ $\pi$ .mrad	$E_{norm}=0.1733\pi$ .mm.mrad $\alpha=-0.105$ , $\beta=1.1194$ mm/ $\pi$ .mrad
Y-Y'	$E_{norm}=0.2090\pi$ .mm.mrad $\alpha=-1.1941$ , $\beta=2.5362$ mm/ $\pi$ .mrad	$E_{norm}=0.1783\pi$ .mm.mrad $\alpha=-1.5975$ , $\beta=3.6565$ mm/ $\pi$ .mrad
Z-Z'	$E_{norm}=0.3301\pi$ .mm.mrad $\alpha=-0.1228$ , $\beta=7.0461$ mm/ $\pi$ .mrad rms Phase=-1.74 ° rms E=0.04 MeV	$E_{norm}=0.4415\pi$ .mm.mrad $\alpha=-0.5693$ , $\beta=30.3660$ mm/ $\pi$ .mrad rms Phase=-22.6 ° rms E=0.005 MeV

### HEBT Structure

Since the preliminary design study phase, various designs have been studied, according to the evolution of physics requirements. In addition, a lot of parameters have to be taken into account: beam dynamics of various ion species at various energies, measurements (beam profiles, position, energy, phase, emittance, current, power loss) using different techniques, quadrupoles, dipoles, and steerers sizes and locations, valves, vacuum pumps... Transport lines cost and building implantation are also some crucial aspects. Finally, a major pressure on the HEBT design is the safety and radioprotection.

Final design, i.e. Fig. 2, takes into account the previous listed parameters.

HEBT lines are designed with a limited number of repeated structures:

- Matching sections composed of 4 quadrupoles are used at the LINAC exit, for the beam dump, and at the entrance of each experimental room,
- Triplet or sextuplet sections are used for transport, with repetitive transverse waists and periodic envelopes,
- Achromatic double deviations are used for beam distribution and protection of targets against energy fluctuations.

The HEBT beam dynamics scheme is such that we have always the same radial envelopes, up to an homothetic, according to the type of beam and the final energy.

For the beam transport in the transverse plane, the most important is to properly match the beam with the first section at 4 quadrupoles as shown in Fig. 3. Quadrupoles

fields are adjusted using 3 diagnostics at equal distances. Same beam size for the two extreme diagnostics (D1 and D3) is required; a central diagnostic (D2) will tune a beam waist with RMS size in both planes verifying relation (1).

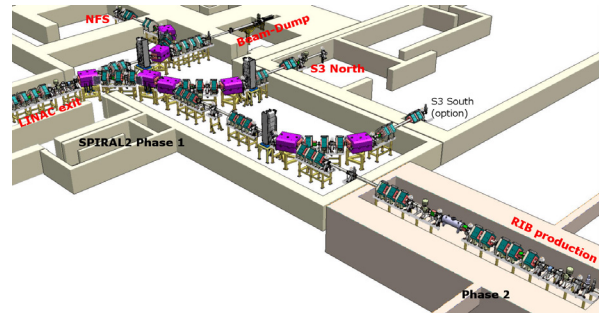

Figure 2: 3D View of the HEBT lines of SPIRAL2.

$$Size_{x,y} = \sqrt{\frac{L \epsilon_n}{\sqrt{3} \beta \gamma}} \quad (1)$$

where L is the distance between 2 consecutives diagnostics (L=1863 mm),  $\epsilon_n$  is the normalized transverse emittance in x and y and  $\beta, \gamma$  the particle speed and the Lorentz factor. RMS Beam size values at the waist diagnostic are from 1.0 mm up to 2.1 mm.

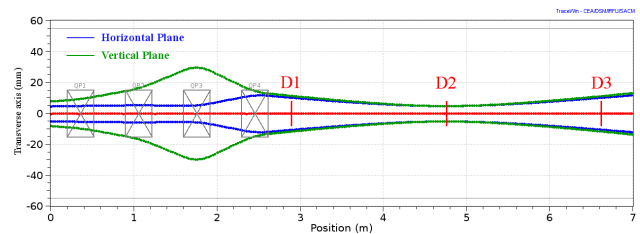

Figure 3: Transverse beam envelopes at 5 RMS for deuterons at 40MeV in the matching section following the LINAC.

An important feature will be the measurement precision and reproducibility provided by secondary emission profilers at low intensity. The impact of this type of errors on HEBT lines have been study. Beam, quadrupoles and measurements errors contributions to beam instabilities are well managed with our design structure. Magnetic steerers location along lines ensure beam alignments around 1mm. Other repeated sections (triplet, sextuplet and deviation sections) are tuned using a magnetic rigidity scale. HEBT total length is 88.7 m and divides in 5 sub-lines

Components in connection with the beam dynamics can be summarized:

- 49 quadrupoles with internal diameter 128 mm,  $L_m=300$  mm (2 families:  $G_{max}=10$  T/m and 13 T/m), 2 quadrupoles with internal diameter 160 mm,
- 8 rectangular dipoles at 45° with  $\rho=1.5$  m, gap=80 mm,  $B_{max}=1.68$  T, P=56 kW,
- 3 SC cavities ( $\beta=0.07$ ) working in buncher mode used to provide very short bunch time lengths required by NFS and S3 (North and South),

- 12 steerers (both transverse planes), one per section+4 vertical correctors in 90° deviation,
- 27 EMS profilers in both transverse plane,
- Beam energy measurement (time of flight method and/or diamond like detector),
- Phase measurement,
- 4 beam position monitors, 11 beam loss monitors
- 12 loss rings with adapted internal diameter,
- Intensity measurements using ACCT, DCCT

We can now present new experimental areas, beam dump cave (Phase 1 of the project) and radioactive ions production area (SPIRAL2 Phase 2). General beam characteristics requirements for the heavy ions will be also given.

## NEUTRONS FOR SCIENCE

The Deuteron and Proton beams delivered by the SPIRAL2 LINAC are particularly well suited to produce high energy neutrons in the 1 MeV – 40 MeV energy range. The NFS area will be composed of mainly two rooms: a converter room where neutrons are produced by the interaction of deuteron or proton beams with thick or thin converters, and an experimental hall with a well collimated pulsed neutron beam. A white neutron source from 1 up to 40 MeV energy range and quasi mono-energetic neutron beam will be available. This facility is of first importance for academic research and applied physics. Several research areas will be covered by NFS like the study of the fission process, the transmutation of nuclear waste, the design of future fission and fusion reactors, the nuclear medicine or the test and development of new detectors, etc. In addition, cross-section measurements of neutron- and deuteron- induced reactions could be realized by activation technique in a dedicated irradiation station [8]. This experimental area will be also used to study materials under irradiation (DPA, neutron damage) in atomics physics fields.

As we can see only light particles beam will concern NFS area: Deuterons, Protons, Helium. For safety reason, maximum current will be limited to 50  $\mu\text{A}$  for D-beam at 40 MeV. Neutrons ToF experiments impose a fast chopper able to select 1/100 beam pulse. The fast chopper is under study, and will take place in the Medium Energy Beam Transport (MEBT) line of SPIRAL2. Beam sizes on targets or converters are 4mm RMS in X and Y with a variable focal point. Neutrons ToF experiments require a short time pulse length ( $\Delta T \sim 1$  ns at  $\pm 3$  RMS) which is almost realized using a  $\beta=0.07$  cavity place before the achromatic deviation along the HEBT line as shown in Fig. 4.

Additional studies have been done on the dynamic of the primary beam (slow down in the converter, deviation using a dipole and stop with a dedicated system). Complementary calculations have been done in order to take into account all the processes in the NFS target area. Careful attention is provided to the full layout of this target room.

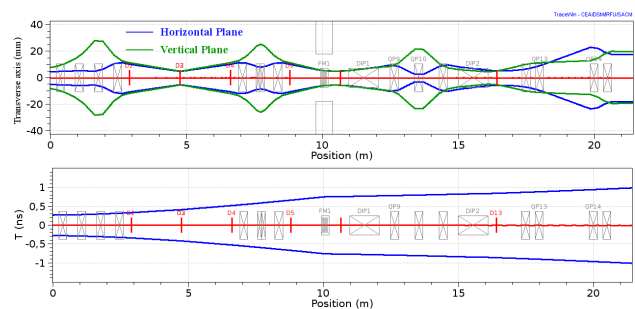

Figure 4: Transverses and longitudinal beam envelopes at  $\pm 5$  RMS for Deuterons beam at 40 MeV, 5 mA from LINAC exit up to NFS area.

## SUPER SEPARATOR SPECTROMETER

S3 is a device designed for experiments using the very high intensity stable beams of LINAC. These beams, which will be provided in a first phase of SPIRAL2 ions with  $A/q=3$  (and in a 2<sup>nd</sup> step  $A/q=6$ ), can reach intensities exceeding 100  $\mu\text{A}$  for lighter ions  $A < 40-50$ . These unprecedented intensities open new opportunities in several physics domains, e.g. super-heavy and very-heavy nuclei, spectroscopy at and beyond the dripline, isomers and ground state properties, multi-nucleon transfer and deep-inelastic reactions. All of the experiments have the common feature of requiring the separation of very rare events from intense backgrounds. S3 will have a large acceptance and clearly must have excellent primary beam suppression. Spectrometer design is based on the conceptual fragment separator proposed by J. Nolen [9].

Primary beam requirements on target are [10]:

- 0.2 ns time pulse length at  $\pm 3$  RMS (in a future phase). This feature imposes to use a  $\beta=0.07$  cavity placed after the deviation as shown in Fig. 2.
- $\Delta E/E < 0.5\%$  at  $\pm 3$  RMS. This feature will be almost fixed by the LINAC characteristics.
- Transverse flat beam, 1 mm in X, 10 mm in Y.

In order to decrease the power density deposited in the rotating target, transverse beam requirements have been carefully studied. First of all, it is theoretically possible to use some sextupoles ([11, 12]). But beam sizes are too small to obtain a stable solution. Otherwise, the variety of beams and energies would impose to have a large set of values for the sextupole tuning. In addition, by using sextupoles, real transverse distributions present large peak power densities at the extreme positions. Distributions are largely sensible to the beam position in the line. This solution was eliminated. According to Shafer remarks [13], we proposed to use a beam sweeper system only in the vertical plane placed after the last quadrupole of the matching line. Final drift up to S3 target is 2.7 m long. The system will be based on the “Direct Double Helix” concept proposed by AML Company [14]. The system is based on 2 shorts 150 mm long dipoles placed at 1 m distance. 5mrad angle is needed to obtain a 10mm total vertical beam painting on target. Second dipole compensates the initial angle in order to suppress the angle contribution to secondary fragments in the S3

separator. Laminated iron yoke must be used in order to work at few kHz.

Beam dynamics studies have been done as shown in Fig. 5. Impacts on the S3 rotating target and beam dynamic in S3 are not yet available. Technical design for the beam sweeper magnet is also under study.

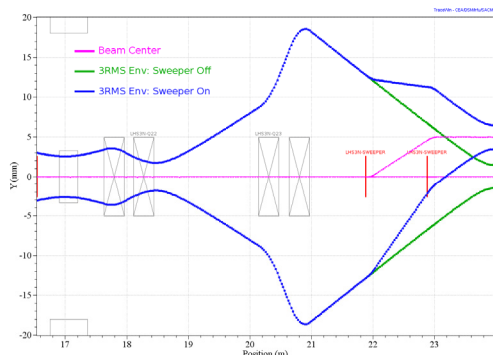

Figure 5: 3 RMS vertical Beam envelopes along the S3 matching section with and without the sweeper magnets.

### BEAM-DUMP

The LINAC Beam dump (BD) is dedicated to the commissioning of the facility, to the beam tuning, control and qualifications. Beam dump must be able to accept 200 kW beam power (40 MeV, 5 mA Deuterons). To restrict area and BD activation, beam power limit will be 10 kW during 1hour per day in normal operation.

The SPIRAL2 beam dump is located at 21 m in the straight line of the LINAC as shown in Fig. 2. BD entrance is located 6.2 m from the last quadrupole which is imposed by a dedicated room. 20 copper blocs of 50 mm long are drilling with internal cone shape to accept around 10 kW beam power each in normal operation. From this basic structure, some improvements have been done [15]. Figure 6 shows the optimized beam-dump geometry profile.

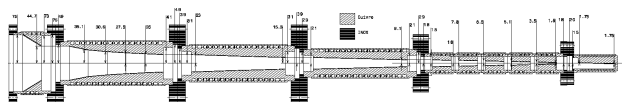

Figure 6: Mechanical design of the SPIRAL2 BD.

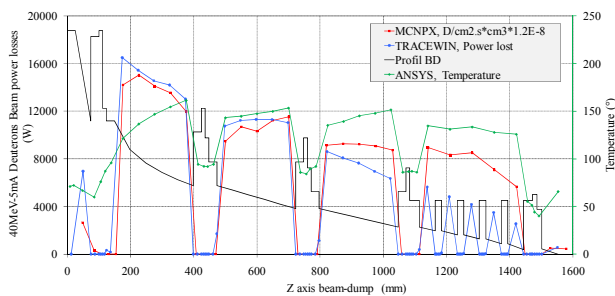

Figure 7: Deposited power 200 kW beam power calculated using TRACEWIN (blue line) with the Deuterons flux calculated using MCNPX [16] (red line) and the temperature profile determined with ANSYS (green line).

Transverse beam characteristics at BD entrance must be independent of the species and their energy. Using last 4<sup>th</sup> quadrupoles, we match the beam to obtain transverse beam distributions at the BD entrance nearby 16mm and 2.8 mrad RMS. Under these conditions, no deposited beam power is observed before the beam-dump.

Safety aspects of the beam-dump have been carefully studies in the framework of the SPIRAL2PP European collaboration project.

### RIB PRODUCTION

As we have already see, the SPIRAL 2 facility will deliver a high intensity, 40 MeV Deuteron beam as well as a variety of heavy-ion beams with mass over charge ratio equal to 3 and energy up to 14.5 MeV/u. Using a carbon converter, fast neutrons from the breakup of the 5 mA of deuterons impinging on a uranium carbide target will induce a rate of up to 10<sup>14</sup> fissions/s. The RIB intensities in the mass range from A=60 to A=140 will be of the order of 10<sup>6</sup> to 10<sup>11</sup> part./s surpassing by one or two orders of magnitude any existing facilities in the world [17]. Other types of primary reaction with light accelerated particles using <sup>3,4</sup>He beam interact with on carbon target as example can also be done.

SPIRAL 2 would allow to perform experiments on a wide range of neutron and proton-rich nuclei far from the line of stability, i.e. Fig. 8, using different production mechanisms and techniques to create the beams. The R&D on RIB production module is particularly challenging.

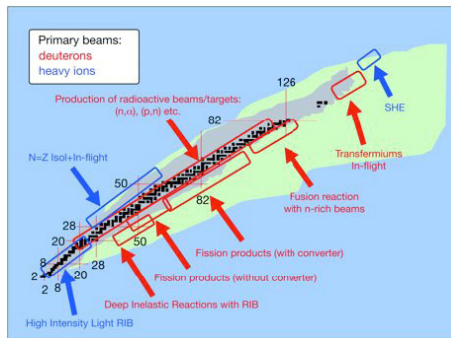

Figure 8: Regions of the chart of nuclei accessible for research on nuclei far from stability at SPIRAL2.

According to the technical risk for the project to start with a 200 kW Deuterons beam on the converter, it has been decided to increase progressively the beam current. That's why, in a first step of operation, beam power will be limited at 50 kW. Objectives are in particular the validation of the carbon converter, target system, safety etc. In addition, for thermo-mechanical constraints, the converter at 50 kW must be representative to the conditions at 200 kW. It is only in a second step that the beam power will increase until the 200 kW nominal value.

In this context, considering a Gaussian beam in X and Y directions, the maximum beam power for 50 kW at the center must be identical to 200 kW. For the full beam

power, size at  $\pm 3$  RMS will be 40 mm. Therefore, the beam size for 50 kW will be 10mm at  $\pm 3$  RMS.

From the HEBT lines point of view, the major constraint comes from the Deuterons beam at 40 MeV and 5 mA current as shown in Fig. 9.

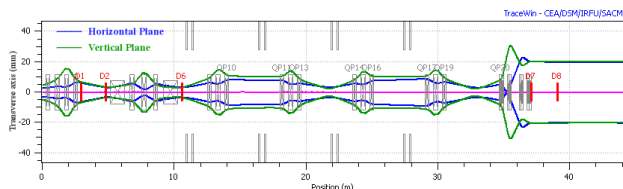

Figure 9: Transverses beam envelopes at  $\pm 3$  RMS for Deuterons beam at 40 MeV, 5 mA from LINAC exit up to RIB production target.

Careful studies are in progress to choose the most appropriated method to control the beam characteristics at high intensity on the converter according the strong radioactivity and contamination.

## CONCLUSION

In this paper, we introduced the status of the High Energy Beam Transport Lines of the SPIRAL2 facility in connection with target location of the experimental areas NFS and S3. The beam dump has been also presented. General aspects about the RIB production line beam optics have been described. In each case, careful attention is taken to provide the beam characteristics required by each end of transport line.

Various beam dynamics studies have been done in connection with safety aspects. The project objective in this field is to have less than 1 W/m beam power loss.

Up to now, new precise errors calculations of the whole machine must be done [18].

Precise mechanical design of the HEBT lines will be available until the end of 2010 which will coincide with the permit for construction grant. First beams will be produced at the beginning of 2012 for stable beams and experimental areas (NFS or S3). RIB production will start for physics experiments at the end of 2014.

## REFERENCES

- [1] T. Junquera et al., "Superconducting Driver Linac for the New Spiral 2 Radioactive Ion Beam Facility GANIL", EPAC06, Edinburgh, Scotland.
- [2] The SPIRAL2 Project Reports 2005-2006 <http://www.ganil.fr/research/developments/spiral2>.
- [3] T. Junquera, "Status of the Construction of the SPIRAL2 Accelerator at GANIL", TU102, LINAC 2008, Vancouver, Canada.
- [4] R. Ferdinand, "SPIRAL2 RFQ Prototype – First Results", MOPCH103, EPAC06, Edinburgh, Scotland.
- [5] G. Devanz et al., "Status of the Low Beta Cryomodules For The SPIRAL2 LINAC", THP007, LINAC 2008, Vancouver, Canada.

- [6] H. Sagnac et al., "RF and Cryogenic Tests for the First Beta 0.12 SPIRAL2 Cryomodule", THP009, LINAC 2008, Vancouver, Canada.
- [7] <http://irfu.cea.fr/Sacm/logiciels/>.
- [8] X. Ledoux on behalf of the NFS Collaboration, "Status Report of the NFS collaboration", December 2008.
- [9] B. Erdelyi et al., "Symmetry-based design of fragment separator optics", Phys. Rev. Spe. Topics, Acc. & Beams, 10, 064002 (2007).
- [10] H. Savajols on behalf of the S3 Collaboration, "Technical Proposal for the Spiral2 Instrumentation: S3 Spectrometer", 2008, December.
- [11] N. Tsoupas et al., "Uniform Particle Beam Distributions Produced by Octupole Focusing", Nuclear Science and Engineering, 126, 71-79 (1997).
- [12] A. J. Jason et al., "Uniform Ribbon-Beam Generation for Accelerator Production of Tritium", M02-58, LINAC88, Cebaf, USA.
- [13] R. E. Shafer, "Comment on Uniformization of the transverse beam profile by means of nonlinear focusing method", Phys. Rev. ST Accel. & Beams, 11, 039001, 2008.
- [14] Advanced Magnet Lab. (AML) Compagny. The Direct Double Helix": <http://www.magnetlab.com/technology/direct-double-helix/robust>.
- [15] E. Schibler et al., "Design of a High Energy Beam Stop for Spiral2 – Studies & Prototype", LINAC2010, Tsukuba, Japan, September 2010.
- [16] D.B. Pelowitz. Ed. MCNPX User's manual, Version 2.5.0, LA-CP-05-0369 (2005). User's Manual, Version 2.6.0, LA-CP-07-1473. J.S. Hendricks et al.: MCNPX 2.6.0 extensions, LA-UR-08-2216 <http://mcnpx.lanl.gov> (2008).
- [17] M-G Saint-Laurent on behalf of the Spiral2 project group, "Future opportunities with Spiral2 at GANIL", AccApp07, Pocatello, Idaho, July 30-August 2nd, 2007.
- [18] R. Duperrier, D. Uriot, "Application of the extreme value theory to beam loss estimates in the SPIRAL2 linac based on large scale Monte Carlo computations", Phys. Rev. ST Accel. & Beams, 9, 044202, 2006.