

A COMPACT SOLUTION FOR DDS-GENERATOR, TURN-ON AND PROTECTIONS IN RADIO FREQUENCY ACCELERATOR SYSTEMS

A. Caruso#, F. Consoli, A. Spartà, INFN-LNS, Catania, Italy
 A. Longhitano, ALTEK, S. Gregorio di Catania, Italy

Abstract

One single compact rack includes: Direct Digital Synthesizer (RF-generator), turn-on and protection devices. The system synthesizes a highly stable RF signal up to 120 MHz, turns the power on in the RF cavities through a step-ramp modulator, and protects the RF system against mismatching, sparks and multipactoring. A first prototype has been designed, assembled and tested on the RF system of the k-800 superconducting cyclotron at Infn-Lns. The hardware, the software, and the preliminary test results, are shown in this paper. This solution is part of the new computer-based RF control system.

CONCEPTUAL DESIGN

One of the most important aims in an RF control system is to supply the power to the cavities. Terms like conditioning and multipactoring are common in all the RF systems [1]. The conditioning, especially of a new cavity, can be really problematic. The stabilization of the right high voltage on the RF electrodes is often a difficult procedure [2]. Proper modulation of the RF signal in the initial conditioning phase is essential to reduce the risk of sparks, high reflected waves and multipactoring phenomena. In the general frame of the k-800 superconducting cyclotron [3] RF control system upgrade, a prototype single board has been developed. It is able to synthesize and modulate the output RF signal and to protect the system. The specific design can reduce the conditioning time remarkably. Moreover, a programmable modulation to bypass multipactoring has been introduced. Figure 1 shows the conceptual block diagram.

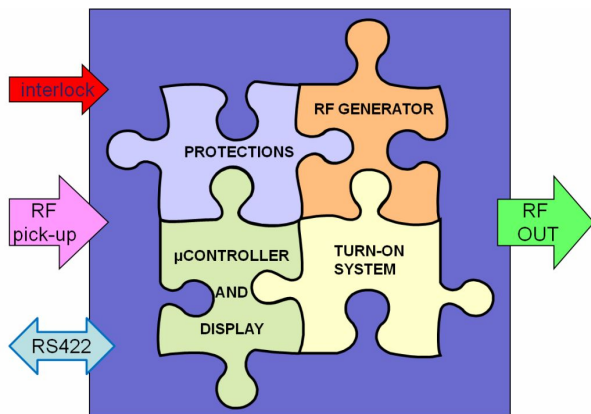

Figure 1: The block diagram of the system.

The puzzle components inside the box summarize the compact concept of the system. The main components

inside the box are: the RF generator, turn-on system, protections, microcontroller and display unit. The RF output, the RF pick-up, the RS422 bus and the interlock line are the external connections of the box. The system is a sort of smart RF synthesizer including important and essential components of a radio frequency low level control system. For this reason we have called it the ‘Low Level RF Box’ (LLRF-Box). On its own it represents half of a typical RF control system. The addition of the stabilization loops (amplitude, phase and tuning) and the control interlock complete the low level RF system. The LLRF-Box can be compatible with most of the cyclotrons and accelerator RF control systems.

LOW LEVEL RF BOX APPLICATION

In general it is common practice that the RF generator, the turn-on system and the protections are placed in separate and independent racks. We came up with the idea of inserting all the components of Figure 1 in a single board during the upgrade of the low level RF system [4].

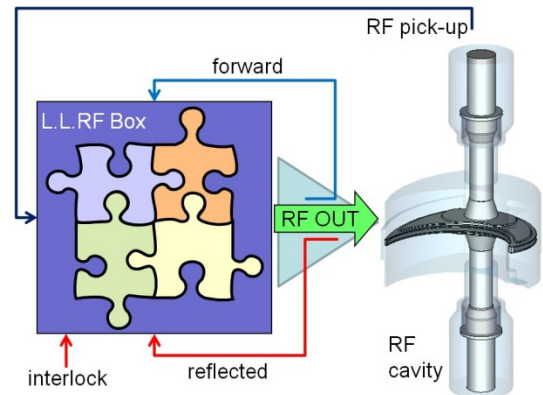

Figure 2: The LLRF-Box connected to the cavity.

The LLRF-Box can be used as a single apparatus for the conditioning of a RF cavity up to 120 MHz. This matches perfectly our RF devices frequency bandwidth at Infn-Lns. The prototype test has been performed on one cavity of the k-800 cyclotron. Figure 2 shows a simple layout where the LLRF-Box is connected to the RF cavity through the amplification section only. The RF box has three RF inputs: forward and reflected wave from the directional coupler and an RF pick-up from the cavity.

THE LOW LEVEL RF BOX

The Low Level RF-Box functions of protections, turn-on and RF-generator are based mainly on the following electronic components: the dsPIC30F4013 by Microchip and the AD9854 by Analog Devices [5,6]. The dsPIC is a

Copyright © 2011 by the respective authors — cc Creative Commons Attribution 3.0 (CC BY 3.0)

#caruso@lns.infn.it

high performance digital signal controller, 16 bit architecture, 80 MHz frequency clock. The AD9854 is the RF generator, based on DDS technique [7]. The bus RS-422 connects LLRF-Box and PC-unit while the SPI digital buses are used inside the block. The LLRF-Box block diagram is shown in Figure 3.

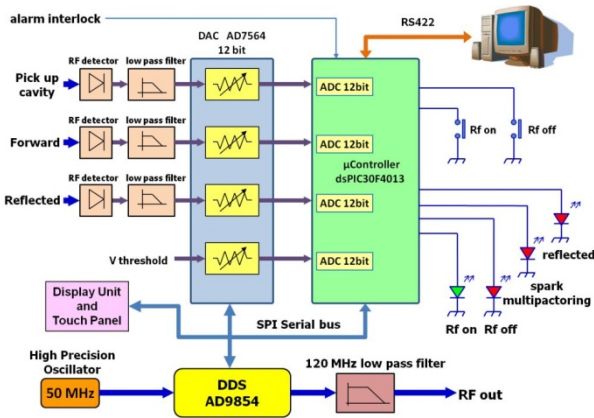

Figure 3: Low Level RF-Box block diagram.

Turn-on System and Protections

The RF inputs are the forward and reflected waves from the directional coupler and the RF pick-up from the cyclotron cavity. After the demodulators and the low pass filters the inputs meet the 12 bit DAC (AD7564). It is an analog attenuator with digital steps. At this stage the input signals are still analog. The reflected wave is compared with the reference threshold voltage, while the pick-up is compared with the forward one. The comparator function is carried out digitally by the dsPIC at the maximum resolution. The dsPIC analog-to-digital converters can exploit all the 12 bit of the comparators to manage the protection and turn-on operations. Under the multipactoring threshold, typically in the cyclotron resonators, the protections work at very low input signal levels, while exceeding this phenomenon the input levels are very high [1,2]. The input values, before the comparators, can be read by test points on the electronic board, displayed on the PC-control panel or directly on the RF-box display unit. In brief, if $V_{\text{cavity}} \leq V_{\text{forward}}$ the system produces an alarm of multipactoring and/or spark. If $V_{\text{reflected}} \geq V_{\text{threshold}}$ the system produces a reflected wave alarm. The thresholds can also be set automatically. In this way the comparison between the signals will follow a dynamic response: small signal levels means lowly attenuated thresholds, large signal levels means highly attenuated thresholds. A front panel cabinet hosts the main functions and indications, such as the main alarms and turn-on/off push-buttons. The resonator's multipactoring effects can be overcome by the proper setting of step and ramp envelope modulation. This is adjustable through the PC control panel, according to the resonance frequency. The pulse mode can be set, if necessary, in case of conditioning. The turn-on sequence, shown in Figure 4, generally feeds the RF power into the k-800 cavities, in one-shot, as shown in the frame *step-ramp-CW*. The *step-*

ramp frame, in the same figure, shows a typical alarm condition: the cavity voltage is turned off and, after an interval of time, the system automatically tries again to turn on the voltage in the cavity. The superimposed signal power spectrums, after the step and the ramp sequences, are shown in the last frame of the figure. This kind of turn-on procedure and modulation technique is a copy of the old RF system. This digital upgraded version allows more freedom in setting and checking the protections and turn-on parameters.

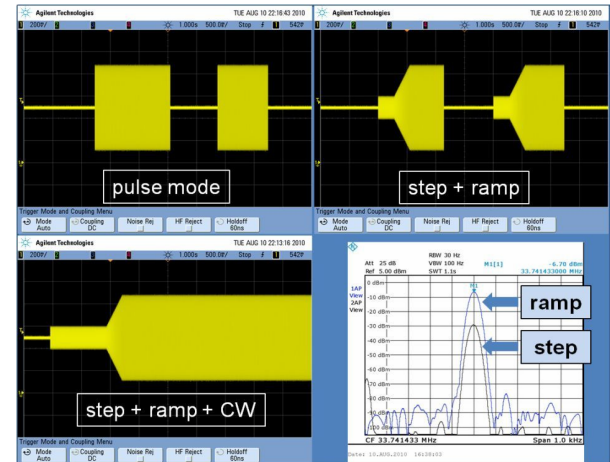

Figure 4: The RF output spectrum and turn-on sequence.

RF Generator

The RF generator is a high frequency source based on the Direct Digital Synthesis technique (DDS) [7]. The DDS technique has been adopted to generate the sine wave for the RF cavity or any other RF load. The initial frequency, amplitude and phase are set by the dsPIC control system without any phase shifter or linear attenuator. The DDS board are based on the electronic component AD9854 by Analog Devices [6]. The system provides a 48 bit frequency resolution together with a highly stable system clock of 300 MHz giving a resolution of 1 μHz , 0.02° in phase, 43 μV in amplitude with a maximum frequency output of up to 120 MHz. The clock source is based on an ultra low noise (-160 dBc/Hz @ 10kHz) high precision oscillator by Valpey Fisher Corporation [8]. A low pass filter is placed at the output stage of the DDS to avoid any residual trace of the waveform digitalization.

FULL POWER TEST

The Low Level RF-Box was successfully tested on March 2010 in the control system of one cavity of the k-800 superconducting cyclotron, at the frequency of 33.74 MHz, with a V_{dec} of around 65 kV. The other two cavities of the cyclotron remained under the traditional RF control system. We ran the RF system at full power with this hybrid configuration for more than one week. No difference was noticed on the accelerated and extracted beam for the whole testing time. The bandwidth of the k-800 cyclotron RF system is between 15 and 50 MHz. The

above test, performed at only one frequency, requires further checking in the near future. The beauty of this system, fully assembled in a three unit 19" rack, is that it is portable. It will soon be used for the complete conditioning of a coaxial cavity of a new chopping beam system at our Lab. It would be a good test bench to operate with the whole functions of the LLRF-Box.

The advantage of using the Box is evident if we focus on the high versatility of the control panel of Figure 5.



Figure 5: Low Level RF-Box control panel.

The in-house visual basic software manages all the functions of the LLRF-Box. During the present power test the control panel has been very useful in setting and reading all the main parameters. The operator can set frequency, amplitude and initial phase of the RF output. The turn-on operation modes can be set in *automatic*, *manual* and *one-shot*. The shape of the trapezoidal envelope signal can be modified in terms of step size, step duration and ramp slope (see Figures 4-6). The setting of the protections can be easily done as well. The control panel allows the setting and reading of $V_{forward}$, $V_{reflected}$, $V_{pick-up}$, $V_{threshold}$. The acquisition of these waveforms in the time domain, like an on-line oscilloscope, can facilitate the setting of the protection parameters to avoid sparks, multipactoring phenomena and mismatching. The setting of the RF system depends on the frequency. Since our cyclotron system is wideband (15-50 MHz), each frequency needs a proper and precise setting. With this control panel, a database can be stored for each frequency settings and the operator can easily recall them when necessary. The detected signal from the cavity pick-up, related to the turn-on sequence during the high power test at 33.74 MHz, is shown in Figure 6. The prototype electronic board is shown too.

The designed step envelope of the turn-on system is extremely fast, and the RF output rise time is equal to a few ns. The detected step of Figure 6 shows instead a rise time of 30 μ s, which is the delay step response of the entire RF system (amplifier, coupler, cavity, etc). In any case, the modulated step has to be fast enough to overtake the multipactoring. From the same detector the step-ramp

signal envelope has been acquired with two different settings of step size and ramp slope. After the step, a stabilization time has been introduced before the final modulation ramp sets the final power to the cavity.

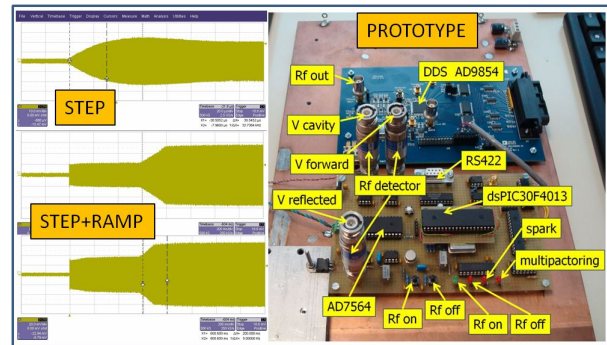

Figure 6: The LLRF-Box and the RF pick-up signal.

FINAL REMARKS

The LLRF-Box is installed in a standard 19" electronic rack and will be part of the cyclotron RF control system of one single cavity. A long time test at different frequencies of the cyclotron RF will be carried out. We are confident we can install the LLRF-Box in the cyclotron's two other cavities and all the INFN-LNS RF systems soon. A further programme of full power test has been scheduled on a new coaxial resonator. The LLRF-Box should be suitable with most of the accelerator RF systems. The versatility of the modulated output signal should match all the RF cavities operating up to 120 MHz. A higher performance version of the LLRF-Box is under study foreseeing a maximum operating frequency of 1 GHz. A more sophisticated programmable envelope modulation of the RF signal is under design, to achieve even higher peak voltages at given time intervals.

REFERENCES

- [1] A. Wu Chao, M. Tigner, Handbook of accelerator physics and engineering, World Scientific Publishing (2009).
- [2] J. Sura, A. Caruso, Multipactoring in the LNS Superconducting Cyclotron, Internal report INFN-LNS, Catania, Italy (1995).
- [3] D. Rifuggiato et al, Japan 16th ICCA, 2004, p.118.
- [4] A. Caruso et al, New PC-Based Control for the RF System at Infn-Lns, ICALEPCS 2009, Kobe, Japan.
- [5] dsPIC30F4013 Microchip, www.microchip.com.
- [6] AD9854 Analog Devices, www.analog.com.
- [7] V. F. Kroupa, Digital Frequency Synthesizers, IEEE Press, 1998.
- [8] Valpey Fisher Corporation, www.valpeyfisher.com.