

PRESENT STATUS OF THE RCNP CYCLOTRON FACILITY

K. Hatanaka*, M. Fukuda, M. Kibayashi, S. Morinobu, K. Nagayama, T. Saito, H. Tamura, T. Yorita, RCNP, Osaka University, 10-1 Mihogaoka, Ibaraki, 567-0047 Osaka, Japan

Abstract

The Research Center for Nuclear Physics (RCNP) cyclotron cascade system has been operated to provide high quality beams for various experiments in nuclear and fundamental physics and applications. In order to increase the research opportunities, the Azimuthally Varying Field (AVF) cyclotron facility was upgraded recently. A flat-topping system and an 18-GHz superconducting Electron Cyclotron Resonance (ECR) ion source were introduced to improve the beam's quality and intensity. A new beam line was installed to diagnose the characteristics of the beam to be injected into the ring cyclotron and to bypass the ring cyclotron and directly transport low energy beams from the AVF cyclotron to experimental halls. A separator is equipped to provide RI beams produced by fusion reactions at low energy and by projectile fragmentations at high energy. A muon capture beam line (MUSIC) was constructed in this spring. Developments have been continued to increase secondary beams as white neutrons, ultra cold neutrons, muons and unstable nuclei.

INTRODUCTION

The Research Center for Nuclear Physics (RCNP) is a national user's facility founded in 1971 and is the major research institute for nuclear physics in Japan. RCNP, as a national laboratory, is open to all users in Japan and from abroad. The cyclotron facility is its major facility and consists of an accelerator cascade and sophisticated experimental apparatuses. Research programs cover both pure science and applications. Demands for industrial applications have been growing more and more.

A schematic layout of the RCNP cyclotron facility is shown in Fig. 1. The accelerator cascade consists of an injector Azimuthally Varying Field (AVF) cyclotron ($K=140$) and a ring cyclotron ($K=400$). It provides ultra-high-quality beams and moderately high-intensity beams for a wide range of research in nuclear physics, fundamental physics, applications, and interdisciplinary fields. The maximum energy of protons and heavy ions are 400 and 100 MeV/u, respectively. Sophisticated experimental apparatuses are equipped like a pair spectrometer, a neutron time-of-flight facility with a 100-m-long tunnel, a radioactive nuclei separator, a super-thermal ultra cold neutron (UCN) source, a white neutron source, and a RI production system for nuclear chemistry. A pion capture beam line was installed to provide muons. Such ultra-high-resolution measurements as $\Delta E/E=5 \times 10^{-5}$ are routinely performed with the Grand-Raiden spectrometer by utilizing the dispersion matching

technique. The UCN density was observed to be 19 UCN/cc at the experimental port at a beam power of 400 W. The white neutron spectrum was calibrated and the flux was estimated to be 70 % of that obtained at Los Alamos Neutron Science Center (LANSCE) in the USA. Neutrons are used for the radiation effect studies on integrated circuits and so on.

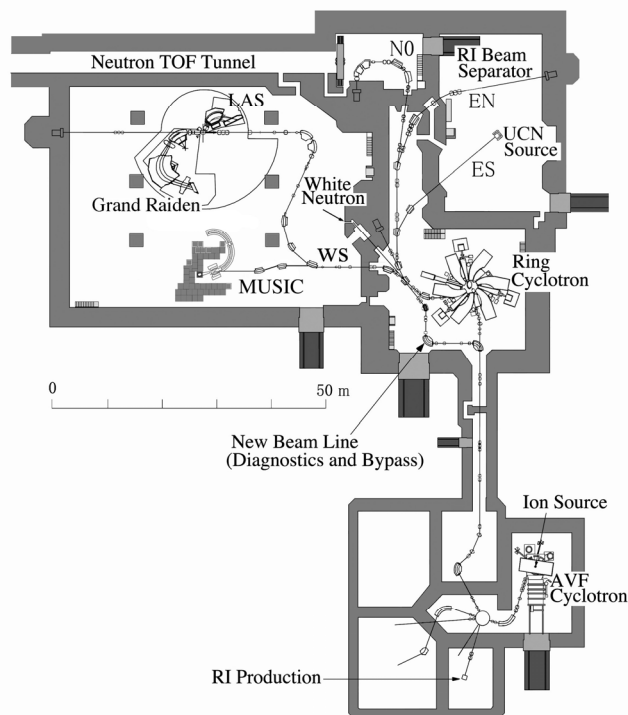

Figure 1: Layout of the RCNP cyclotron facility.

ACCELERATOR DEVELOPMENTS

User's demands on the beam characteristics are expanding rapidly: ultra-high resolution, high intensity, a variety of heavy ions. Since there are no slits or collimators in the beam lines downstream of the ring cyclotron, the beam quality on targets is determined by the characteristics of the injected beam. The AVF upgrade program for these items is in progress [1-3]: Some of them are presented in these proceedings [4,5].

ECR Ion Source

An 18-GHz superconducting ECR ion source was installed in order to increase beam currents and to extend the variety of ions, especially for highly-charged heavy ions, which can be accelerated by RCNP cyclotrons. The production development of several ions beams and their acceleration by the AVF cyclotron has been performed since 2006.

*hatanaka@rcnp.osaka-u.ac.jp

Figure 2 shows a cross sectional view of the source. The source was designed based on RAMSES [6] at RIKEN, but the inner diameter of the hexapole magnet and of the plasma chamber were extended to 90 and 80 mm, respectively, based on the experience during their developments. The mirror magnetic field is produced with four liquid-helium-free superconducting coils, which are cooled by two Gifford-McMahon refrigerators and which are installed in a cryostat chamber covered by iron magnetic shields. Upstream coil 1 (U1) and downstream coil (D) are of the same size and are excited in series by using a common power supply. Central coil (C) and upstream coil 2 (U2) are excited by using independent power supplies, and the mirror magnetic field distribution is controlled quite flexibly. Typical operating currents are 36.3 A, 36.9 A, and 60.5 A for the U1+D, C, and U2 coils, respectively. The maximum current for each coil is 66 A. The permanent magnet hexapole is of the Halbach type, with 24 pieces of NEOMAX-44H material. The radial field strength is 1.0 T on the stainless-steel plasma chamber's inner diameter. The diameter and the length of the plasma chamber are 80 mm and 380 mm, respectively.

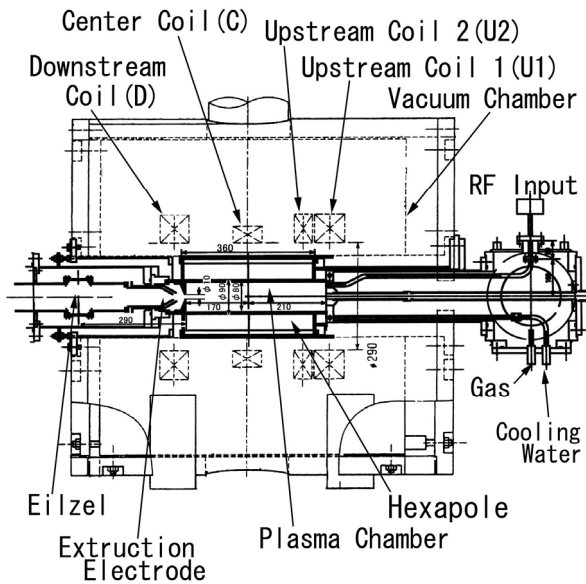

Figure 2: Cross-sectional view of a liquid-helium free 18-GHz superconducting ECR ion source.

In order to improve the performances of the source, a liner was inserted. A bias probe was installed on the beam axis on the injection side. The maximum applicable voltage is -500 V relative to the plasma chamber, and the probe position is variable between 120 and 220 mm from the center of the C coil. The optimum position is located at 170-190 mm, which corresponds to the position of the maximum mirror field. The extraction system is composed of two electrodes and can be moved along the beam axis. An einzel lens is placed downstream of the extraction electrode.

The ion beams extracted from the source are analyzed by using a dipole magnet and are measured in a Faraday

cup placed at the image focal point of the analyzing system. Detailed performance of the source is presented somewhere in these proceedings [4]. 8.5 MeV/u $^{86}\text{Kr}^{23+}$ beams were accelerated by the AVF cyclotron and were delivered to user's experiments. In order to produce metallic boron-ions, a test by using the MIVOC (Metal Ion from Volatile Compounds) method [7] was performed using o-carborane ($\text{C}_2\text{B}_{10}\text{H}_{12}$). Its vapour pressure was around 1-2 Torr at the room temperature. The stable flow of the vapour from the o-carborane powder to the plasma chamber enabled us to produce a fully stripped boron ions. The o-carborane was put in a glass vessel directly connected to the plasma chamber via a buffer tank. A helium gas was used to generate plasma.

2.45 GHz ECR Proton Source

A proton source is under development to supply high currents with a low emittance. It consists of three ring permanent magnets and no multipole magnets are employed. Performance tests were finished and 0.6 mA protons were extracted at 15 kV and with a relatively low RF power of 200 W. The source has been installed in the injection beam line. On-line tests will start this fall.

Flat-Topping Acceleration System

A schematic layout of the main and the flat-top resonators of the AVF cyclotron is shown in Fig. 3. An additional flat-top cavity of a coaxial movable-short type is inductively coupled to the main resonator on the opposite side of the main power feeder for fundamental-voltage production. The flat-top cavity has a length of 700 mm and an outer diameter of 170 mm. A full stroke of the shorting plate of the flat-top cavity is 100 mm. The coupler electrode and the inner conductor of the flat-top cavity are shown in Fig. 3. The gap between the coupler electrode and the inner tube of the main cavity can be changed from 0 to 155 mm. Fine adjustment for 50Ω impedance matching is accomplished by using a tuner with a full stroke of 40 mm.

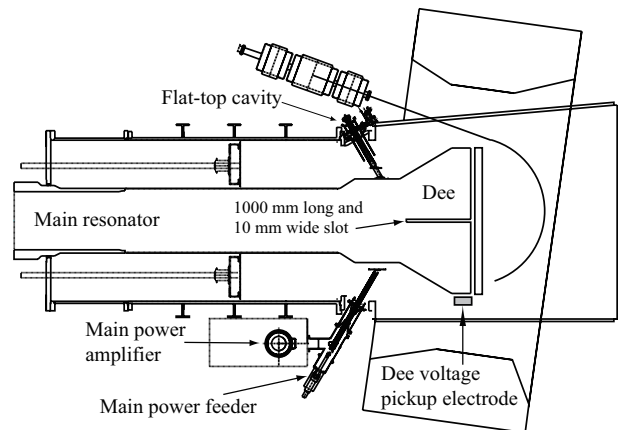

Figure 3: Cross-sectional view of a liquid-helium free 18-GHz superconducting ECR ion source.

A flat-topped dee voltage waveform can be generated by superimposing a harmonic voltage on the fundamental

one [8]. The RF power from a 10-kW transistor amplifier is transmitted to the flat-top resonator through a coaxial waveguide (WX39-D) and is inductively fed to the Dee electrode. Impedance matching of the 50Ω transmission line from the flat-top cavity to the main resonator is optimized by adjusting the positions of the coupler, the shorting plate, the tuner, and the feeder capacitor. Impedance matching can be achieved over a wide range of harmonic frequencies from 50 to 80 MHz. Hence, the fifth, seventh, and ninth harmonic modes are available for production of the flat-topped voltage waveform. Such higher order harmonic modes have an advantage of saving power for the harmonic voltage production, because the n -th harmonic voltage required for flat-topped waveform production is $1/n^2$ of the fundamental one [5, 9]. For the present structure of the Dee electrode, a parasitic resonance mode is known to exist around 76 MHz. This resonance is generated in the transversal direction of the dee electrode axis. There is some possibility of the parasitic resonance's interference with the fifth harmonic voltage production for the flat-top acceleration of higher energy protons. In order to shift the transversal resonance frequency to around 55 MHz, we put a 1000-mm-long and 10-mm-wide slot along the electrode axis, as shown in Fig. 3. Beam developments are on-going with the FT system [5].

RESEARCH PROGRAMS

Beams are available on targets for 5000-6000 hours in a year. A wide range of research programs are performed at the RCNP cyclotron facility as listed below.

- Few-body problem
- Nucleon and nuclear interactions in nuclear medium
- Proton/deuteron elastic & inelastic scattering (p,2p), (p,n) reactions
- Charge exchange reactions relevant to the astronuclear physics: ($^4\text{He}, ^6\text{He}$), ($^4\text{He}, ^8\text{He}$)
- Giant resonance excited by (p,p'), ($^3\text{He}, t$), (α, α'), ($^7\text{Li}, ^7\text{Be}$) γ reactions
- Fragmentation of deep hole states in light nuclei
- Proton-proton Bremsstrahlung (p,p' γ) reaction
- Weak hyperon nucleon interaction by the pn \rightarrow p Δ reaction
- Heavy ion physics with rare isotopes
- Fundamental physics with ultracold neutrons
- Applications (neutrons)
 - Material science
 - Biological science
- Nuclear chemistry

Intensive studies have been performed on the spin and isospin excitation by charge exchange (p,n) and (n,p) reactions around 300 MeV. The $\sigma\tau$ nucleon-nucleon interaction has the maximum strength at this energy region. The mechanism of these reactions is simple, as well. We can extract the spin and isospin excitation strength with least ambiguities. Recent result showed the strength distribution in the nuclei relevant to 2 ν double β decays [10].

A beam line was installed to bypass the ring cyclotron and to directly deliver low-energy, high intensity beams from the AVF cyclotron to experimental halls. It increases research opportunities at the cyclotron facility as well as diagnoses the quality of the beam injected into the ring cyclotron. With this line, low energy heavy ions are delivered to the rare isotope separator and are used to study high spin isomeric states in nuclei. Owing to low backgrounds at the second target area, decaying γ rays can be clearly observed from isomeric states. A new beam line was installed to capture pions by superconducting solenoid magnets. Muons are produced in succeeding decay channel.

REFERENCES

- [1] Hatanaka, T. Itahashi, M. Itoh, M. Kibayashi, S. Morinobu, K. Nagayama, S. Ninomiya, T. Saito, Y. Sakemi, K. Sato, A. Tamii, H. Tamura, and M. Uraki, Proceedings of the 17th International Conference on Cyclotrons and their Applications, Tokyo, Japan, pp. 115-117 (2004).
- [2] Fukuda, H. Tamura, T. Saito, T. Yorita, and K. Hatanaka, Proceedings of the 18th International Conference on Cyclotrons and their Applications, Giardini Naxos, Italy, pp. 470-472 (2007).
- [3] Hatanaka, M. Fukuda, M. Kibayashi, S. Morinobu, K. Nagayama, H. Okamura, T. Saito, A. Tamii, H. Tamura, and T. Yorita, Proceedings of the 18th International Conference on Cyclotrons and their Applications, Giardini Naxos, Italy, pp. 125-127 (2007)
- [4] T. Yorita et al., in these proceedings, MOPCP051
- [5] M. Fukuda et al., in these proceedings, MOPCP056.
- [6] T. Nakagawa, T. Aihara, Y. Higurashi, M. Kidera, M. Kase, Y. Yano, I. Arai, H. Arai, M. Imanaka, S. M. Lee, G. Arzumanyan, and G. Shirkov, Rev. of Sci. Instru. 75, 1394 (2004).
- [7] H. Koivisto, E. Kolehmainen, R. Seppala, J. Arje, and M. Numia, Nucl. Instr. Meth. Phys. Res. B117, 186 (1996).
- [8] J. L. Conradie, A. H. Botha, J.J. Kritzinger, R. E. F. Fenemore, and M. J. Van Niekerk, Proceedings of the 14th International Conference on Cyclotrons and their Applications, Cape Town, South Africa, pp. 249-251 (1995).
- [9] M. Fukuda, S. Kurashima, S. Okumura, N. Miyawaki, T. Agematsu, Y. Nakamura, T. Nara, I. Ishibori, K. Yoshida, W. Yokota, K. Arakawa, Y. Kumada, Y. Fukumoto, and K. Saito, Rev. Sci. Instru., 74, 2293 (2003).
- [10] K. Yako, M. Sasano, K. Miki, H. Sakai, M. Dozono, D. Frekers, M. B. Greenfield, K. Hatanaka, E. Ihara, M. Kato, T. Kawabata, H. Kuboki, Y. Maeda, H. Matsubara, K. Muto, S. Noji, H. Okamura, T. H. Okabe, S. Sakaguchi, Y. Sakemi, Y. Sasamoto, K. Sekiguchi, Y. Shimizu, K. Suda, Y. Tameshige, A. Tamii, T. Uesaka, T. Wakasa, and H. Zheng, Phys. Rev. Lett. 103 (2009) 012503.